

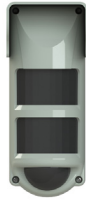

RiDom

Outdoor motion detector «Ri-OMD-1i»



Installation guide

1 GENERAL INFORMATION

1.1 Outdoor motion detector «Ri-OMD-1i» (hereinafter referred to as the detector) monitors the unauthorized penetration into the secured area and transmits notifications via a two-way radio channel using the «Ri-Contact-Ri» protocol.

1.2 The detector works as part of the RiDom smart home security system, communicating with the «Ri-HUB-1i» control center (hereinafter referred to as the Hub) using the «Ri-Contact-Ri» radio channel protocol.

1.3 The Detector does not require licensing and registration as the radio frequency device.

1.4 The detector performs the following operations:

a) it generates and ensures the transmission of the following notifications over the radio channel:

- «Normal» – in the absence of other notifications;
- «Alarm» – when an intrusion into the secured area is detected;
- «Opening» – when the detector housing case is open;
- «Discharge of the main battery» – when the supply voltage of the main battery drops below 2.4-0.4 V;
- «Reserve battery discharge» – when the backup battery supply voltage drops below 2.4-0.4 V.

b) it generates the following types of indication:

- «Linking» – when registering the detector in the Hub;
- «Identification» – when the detector receives the appropriate command from the Hub.

1.5 The detector includes:

- three passive IR channels for provision of reliable detection of penetration into the secured area;
- two-color light indication (red and green colors) of the detector shows the status and the quality of communication with the Hub at the place of installation;
- RESET jumper to switch the detector into the «Linking» mode;
- case opening sensor;
- a temperature sensor for subsequent transmission of the temperature information to the Hub for ensuring the corresponding temperature compensation of the detecting ability.

1.6 Two frequencies are used for the exchange of radio signals between the detector and the Hub - the main and the backup. Transition to a backup frequency happens automatically.

1.7 The detector is resistant to:

- movement of animals weighing up to 20 kg within the detection zone;
- exposure to changes in background illumination up to 20,000 lux;
- changing the background temperature at a rate of up to 5 °C/min.

1.8 The detector is resistant to electromagnetic interference.

1.9 The design of the detector ensures its round-the-clock operation outdoors.

2 SPECIAL FEATURES

The position of the detection zone can be adjusted using the mounting bracket. A visor is provided to protect the sensor from precipitation.

3 SPECIFICATIONS

Table 1

Parameter	Value
Frequency range	865...867 MHz
Radiation power, no more	25 mW
Detection zone	volumetric
Maximum detection range	12 m
Permissible installation height	2 - 3 m
Detection zone view angle in the horizontal plane	90°
Protection class	IP54
Battery type	CR123A, 2 pcs.
Dimensions	180x75x80 mm
Weight	0,2 kg
Duration of operation from batteries under normal climatic conditions and with a broadcast period of 60 s	8 years
Average service life	8 years
Operational conditions	
Operating temperature range	-40... +55 °C
Temperature measurement tolerance	±2,0 °C
Permissible air humidity at a temperature of +25 °C, with moisture condensation	Up to 100 %

4 SCOPE OF SUPPLY

Table 2

Name	Qty.
Outdoor motion detector «Ri-OMD-1i»	1 pc.
Visor	1 pc.
Installation bracket	1 pc.
Antenna	1 pc.
Dowel NAT 5x25	2 pcs.
Screw 3-3x30,016	2 pcs.
Lithium battery CR123A	2 pcs.*
Plastic sealant	1,0 ± 0,5 g
Installation guide for the «Ri-OMD-1i»	1 copy
* Installed	

5 VIEW AND DESIGN

The detector (picture 1) consists of a base (1), a printed circuit board (3) and a case cover (6). There are holders for two CR123A batteries on the printed circuit board - main (5) and backup (4), three IR pyro receivers (9), antenna (10), included in the set, two-color light indicator (11), case opening sensor (12) and RESET contacts (13). The printed circuit board is fixed to the base with a latch (14) and a screw (8). The cover (6) is attached to the base (1) with four screws (7) using a sealing gasket.

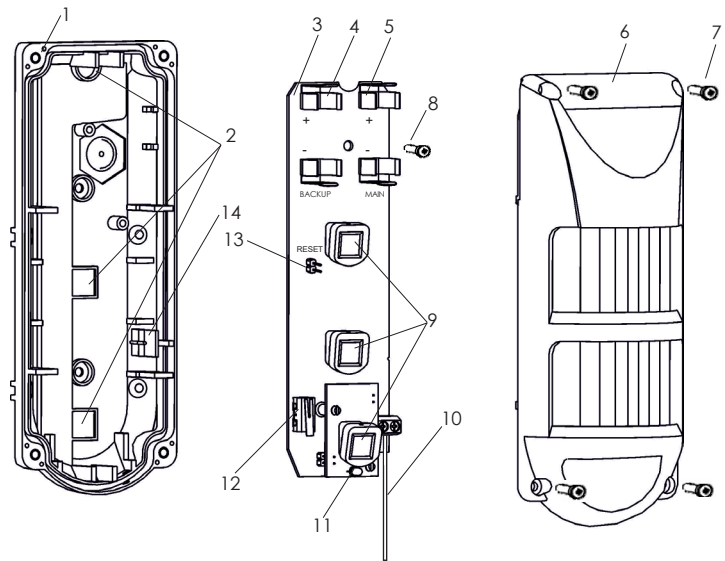

Picture 1 – «Ri-OMD-1i» view

6 INDICATION

Table 3

LED status	Indication	
	Action	Action
«Linking»	Intermittent green LED	
«Alarm»*	Turning on the red LED for 0,5 s	If indication is enabled
«Identification»	Alternating switching of red and green LEDs with a frequency of 1 Hz	On command from the Hub
«Connection quality»	See the section «Assessing the quality of connection»	
Completing the linking process	Turning on the red LED for 2 s	

* The alarm indication turns off 15 minutes after the sensor cover is closed and turns on when it is opened or at the command of the Hub.

7 CHOOSING THE PLACE OF INSTALLATION

The The detection zone diagram (Picture 2) must reliably cover the entire monitored zone. It is recommended to install the detector at a height of (2.3 ± 0.1) m. The monitoring zone of the detector should not be blocked by opaque or translucent objects (tree branches, bushes, mesh fences). If possible, there should be no objects in the field of view of the detector which temperature can change dramatically, for example, sections of a wall heated by the sun.

The quality of the radio connection between the detector and the Hub in the site of intended installation must ensure reliable transmission of notifications (for assessment of the quality of communication, see clause 9).

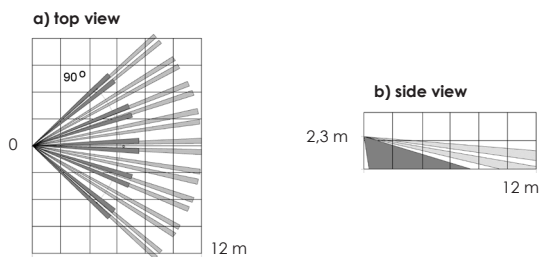

Picture 2 – Detection zone diagram

8 CONNECTING THE DETECTOR TO THE SYSTEM

8.1 Open the RiDom application and click **+** in the My Devices tab. Then press **Add device** button. Select the «Ri-OMD-1i» detector from the list of devices and follow the prompts in the application.

8.2 When prompted by the application, remove the battery isolator.

8.3 The Detector will periodically turn on the green LED, which indicates that it is in the «Linking» mode.

8.4 Upon successful connection to the Hub, the indicator on the Detector will turn red for 2-3 seconds, then you can see the Detector in the application, as well as all the information about the Detector. Linking mode time is limited to 100 seconds. To resume the «Linking» mode, it is necessary to briefly close the «RESET» contacts.

8.5 The sensitivity of the detector is adjusted through the mobile application according to the table parameters.

Table 4

Sensitivity	Maximum distance, m
Low	8
Average	10
Maximum	12

8.6 Install the cover.

9 RADIO CONNECTION QUALITY ASSESSMENT

Before installing the detector at the place of installation, it is advisable to check the quality of communication with the Hub.

The following steps are recommended to be made:

1. Place the ready for operation detector with the closed cover at the installation site.

2. Open the detector case, and the detector will indicate the quality of communication with the Hub.

Table 5 – Indication of the communication quality control results

Indication		Connection quality	Recommendations
Color	Mode		
Green	Three blinks	Perfect	Installation in this location is allowed
Green	Two blinks	Good	
Green	One blink	Weak	
Red	Four blinks	No connection	Choose a different installation location or use a repeater

10 INSTALLATION

10.1 Assemble the supplied bracket:

- insert the nut into the sphere;

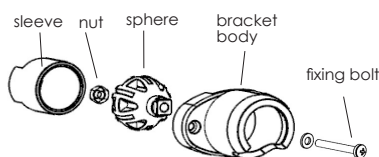

Picture 3 – Bracket parts

- put a sphere into the base of the bracket;
- insert the sleeve into the base of the bracket.

10.2 Attach the assembled bracket with screws to the wall (ceiling) at the place of installation. The body of the bracket can be used as a template for marking the mounting holes on the surface.

10.3 Attach the base to the installed bracket with the fastening screw, passing it through one of the holes (2).

10.4 After attaching the base to the bracket, seal the hole (2) with the supplied sealant.

10.5 Put the printed circuit board in the place, secure it with the latch (14) and screw (8).

10.6 Connect the antenna (10) through the hole in the base of the detector case to the printed circuit board and fix it with a screw.

10.7 Close the cover of the detector, place it in a vertical position and turn the case so that the detector would look in the chosen direction.

11 SET UP AND SETTINGS

11.1 The detector setup includes adjusting the position of the detection zone and selecting the sensitivity of the detector.

11.2 To determine the actual boundaries of the detection zone, it is necessary to start moving through the detection zone at a speed of 0.5–1 meter per second.

11.3 During the first 15 minutes after closing the case cover of the detector, the «Alarm» notification is duplicated by a short-term red indicator light.

11.4 Changing the position of the detection zone is achieved by turning the detector case in the bracket.

If «Alarm» notification within is generated in the detection zone at the absence of any movement, it means there is a complex interference situation. In this case, it is recommended to limit the sensitivity of the sensor.

After changing the sensitivity, check the boundaries of the detection zone. The light indication of the «Alarm» notification automatically turns off 15 minutes after the detector case cover is closed. If it is necessary to continue the adjustment of the detector, remove and reinstall the detector case cover back.

The detector operating modes
The detector has three modes of operation «Disarmed», «Armed» and «Identification». The modes are switched by radio commands from the Hub.

In the «Disarmed» mode, an alarm notification is transmitted immediately with the initiation of an emergency radio exchange session, a «Normal» notification is transmitted during regular radio exchange sessions. In the Armed mode, any change in status is transmitted immediately with the initiation of a new radio session. In the «Identification» mode on alternate indication in red and green colors is activated for 15 minutes on the receiving of the address command from the Hub (see Table 3). The «Identification» mode allows to find the detector with a given address.

12 STORAGE AND TRANSPORTATION

12.1 The Detectors in their original packaging are resistant to:

- transport jolting with the acceleration up to 30 m/sec² at impact frequency range from 10 to 120 per minute or 15 000 strikes;
- ambient temperature range minus 50 ... +55 °C;
- relative air humidity (95 ± 3) % at a temperature +35 °C.

12.2 The Detectors in original package may be transported by any means of transportation in closed vehicles over any distances in compliance with the existing shipping rules concerning the respective means of transportation.

12.3 After transportation under the conditions different to exploitation conditions the Detectors shall be ready to operate after a maximum of six hours.

12.4 During storage period lithium batteries should be removed from the holders or isolators should be installed.

Note: The storage premises should not contain any current-conducting dust, acid and alkali fumes, or corrosive or destroying insulation gases.

13 DISPOSAL INFORMATION

13.1 The Detector does not contain precious metals, hazardous or toxic substances that can harm human health or the environment, and does not pose a danger to life, human health and the environment at the end of its service life.

13.2 In this regard, the disposal of the Detector can be carried out according to the rules for the disposal of general industrial waste.

14 MANUFACTURER WARRANTY

14.1 LLC NPP RIELTA guarantees that the Detector meets the requirements of technical specifications within 27 months from the date of manufacture, subject to the conditions of transportation, storage, installation and operation.

14.2 Warranty period of operation of the Detector is 24 months from the date of commissioning within the warranty period of storage.

14.3 If during the warranty period the Detector, which is subject to the rules of transportation, installation and operation, is found to be inconsistent with the requirements of the technical specifications, it is to be replaced or repaired by the manufacturer.

15 DATE OF MANUFACTURE

_____ month, year



rldom.ru

Made in Russia

v13/v13.1