



RiDom

Glass break detector «Ri-GBD-1i»



Installation guide

1 GENERAL INFORMATION

1.1 Glass break detector «Ri-GBD-1i» (hereinafter referred to as the Detector) detects the destruction of sheet glass and double-glazed windows blocks.

1.2 The Detector works as part of the smart home security system RiDom and transmits the following notifications via radio channel to the «Ri-HUB-1i» control center (hereinafter referred to as the Hub):

- «Norm» - in absence of destructive effects on the secured glass;
- «Alarm» - upon detection of destructive effects on the secured glass;
- «Opening» - when the Detector case is opened;
- «Battery discharge» - when the battery supply voltage drops.

1.3 The Detector does not require a permit for purchasing and use and is not subject to registration and licensing.

1.4 The Detector is resistant to electromagnetic interference.

1.5 The Detector is designed for continuous round-the-clock operation.

1.6 According to the number of detection zones, the Detector belongs to two-zones type of the detectors.

2 FIELD OF APPLICATION

The Detector can be used in offices, shops, museums, showrooms, banks, residential areas, etc.

3 SPECIFICATIONS

Table 1

Параметр	Значение
Frequency range	865... 867 MHz
Radiation power	25 mW
Maximum range, not less than:	
- with the area of protected glass 0.1 m ² ;	6 m
- when the area of protected glass is more than 1 m ²	9 m
Viewing angle	120°
Installation height, not less than	2 m (according to pictures 4 - 8)
Battery type	CR123A, 1 pc.
Dimensions	80x80x38 mm
Weight	0.1 kg
The degree of protection provided by the shell	IP30
Average service life	8 years
Operational conditions	
Operating temperature range	from -20 to +55 °C
Relative air humidity at +25 °C	up to 98%

4 SCOPE OF SUPPLY

Table 2

Name	Qty
Glass break detector «Ri-GBD-1i»	1 pc.
Lithium battery CR123A	1 pc.*
Installation guide for the «Ri-GBD-1i»	1 copy
* Included	

5 VIEW AND DESIGN

The Detector consists of a cover with a light window and a base (1) with a printed circuit board (2).

The printed circuit board (2) is fixed on the base (1) with two screws (3).

The printed circuit board (2) contains: antenna (4), «RESET» jumper (5), tamper sensor (6), two-color LED indicator (7), battery holder (8) and microphone (9).

The base (1) has two mounting holes (10) for attaching the Detector to the place of installation.

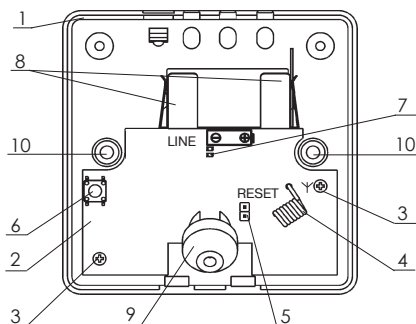

Picture 1 – Top view with removed cover

6 INDICATION

The indication will automatically turn off 10 minutes after the lid is closed. Open the case cover again to resume the indication.

Table 3

Detector status	Indication	Notes
«Normal»	Off	
«Obstruction»	Green LED is ON	For the duration of the interference
«Alarm»	Single red light for 3 seconds	
«Opening»	See «Connection quality assessment»	
«Linking»	Intermittent green light	Registration of the sensor in the Hub
«Identification»	Alternating red and green lights	The corresponding command was received from the hub
«Connection quality»	See «Connection quality assessment»	

7 CHOOSING PLACE OF INSTALLATION

Before installing the sensor, please read the following requirements:

- it is recommended to install the sensor at a height of at least 2 m (see installation examples in figures 4-8);
- when choosing the installation location, take into account the radiation pattern of the sensor (Figure 2);

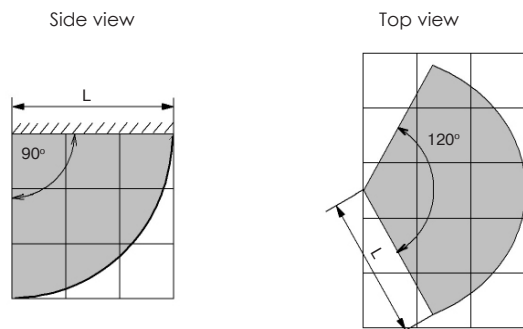

Picture 2 – Detection zone

- the distance (L) from the Detector to the most remote point of the secured glass should not exceed 6 m;

- when operating together with an active ultrasonic detector, the distance between them must be at least 1 m;

- all sections of the secured glass must be within the line of sight of the Detector.

The Detector must be in the radio visibility zone of its Hub, so it is recommended to evaluate the quality of communication with the Hub from the place where the Detector is planned to be installed.

Do not install the Detector under the following conditions:

1. In close proximity to electrical wiring.
2. Near metal objects and mirrors that cause attenuation of the radio signal or shield it.
3. Outdoors.
4. In rooms with temperature and humidity beyond the permissible values.

8 CONNECTION TO THE SYSTEM

8.1 Open the RiDom application. In the My Devices tab, click and then . Select the «Ri-GBD-1i» detector from the list of devices and follow the prompts of the application.

8.2 When prompted by the application, remove the battery isolator.

8.3 The Detector will periodically turn on the green indicator; it shows that it is in the «Linking» mode.

8.4 Upon successful connection to the Hub, the indicator of the Detector will turn red for 2-3 seconds, then you can see the Detector in the application, as well as all the information about the Detector. Linking mode time is limited to 100 seconds. To resume the «Linking» mode, it is necessary to briefly close the «RESET» contacts.

8.5 Install the Detector case cover.

9 MOUNTING

Remove the case cover to install the Detector.

Having chosen the location for the installation of the Detector, make markings for drilling the mounting holes. A base can be used for marking (see Figure 3).

Fix the base to the place of installation with screws.

Dimensions (mm)

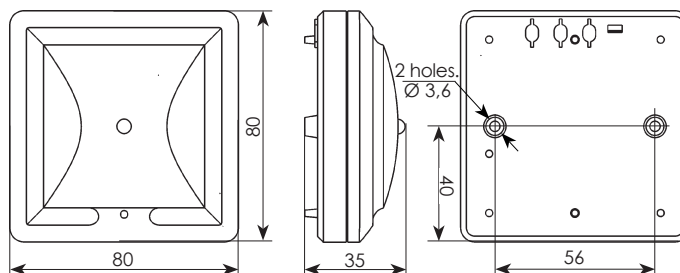

Picture 3 – Case base view

10 EXAMPLES OF INSTALLATION

Pictures 4-8 show options for the correct installation of the Detector, Picture 9 shows incorrect installation.

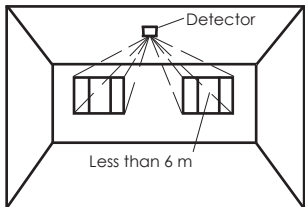

Picture 4 – Ceiling installation

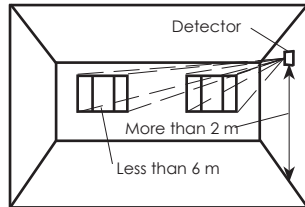

Picture 5 – Side wall installation

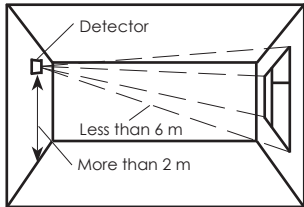

Picture 6 – Opposite wall installation

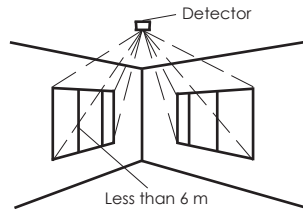

Picture 7 – Ceiling installation (in order to control windows in adjacent walls)

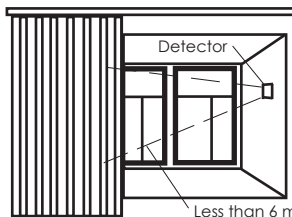

Picture 8 – Installation of the detector between glass and a curtain

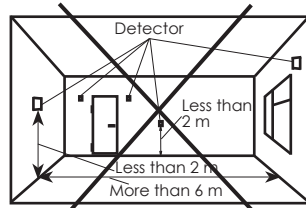

Picture 9 – Inappropriate places of installation

11 CONNECTION QUALITY ASSESSMENT

To assess the quality of the radio communication between the Detector and the Hub, it is necessary to:

1. Place the registered Detector at the site of installation.
2. Remove the cover. At the same time, the Detector transmits a notification about the opening of the case and the quality of communication with the Hub is indicated by a three-point scale with a green indicator (see table 4).

Table 4

Indication		Connection quality	Recommendations
Color	Mode		
Green	Three blinks	Perfect	Installation in this location is allowed
Green	Two blinks	Good	
Green	One blink	Weak	
Red	Four blinks	No connection	Choose a different installation location or use a repeater

12 SENSITIVITY ADJUSTMENT AND PERFORMANCE TEST

Install a lithium battery or remove the insulator tab. Close the lid. Activation of a green LED indicator says that there is the interference in the room. Eliminate sources of interference wherever possible.

Adjusting the sensitivity of the Detector allows to set its operating range and detectability.

To set the sensitivity correctly, see table 4.

Table 4

Minimum glass side length	Maximum distance to the glass		
	6 - 3 m	3 - 1 m	Less than 1 m
from 0,3 m to 1 m	max (3)	max (3)	-6 dB (2)
1 m and more	max (3)	-6 dB (2)	-12 dB (1)

If the Detector is installed in a window hole, the microphone may not be directed at the controlled glass. In this case, always set the maximum sensitivity.

Changing of the sensitivity level is carried out by sending a command from the Hub.

Note – the maximum sensitivity of the Detector is set automatically when registering in the RiDom system.

13 STORAGE AND TRANSPORTATION

13.1 The Detectors in their original packaging are resistant to:

- transport jolting with the acceleration up to 30 m/sec² at impact frequency range from 10 to 120 per minute or 15 000 strikes;
- ambient temperature range minus 50 ... +55 °C;
- relative air humidity (95 ± 3) % at a temperature +35 °C.

13.2 The Detectors in original package may be transported by any means of transportation in closed vehicles over any distances in compliance with the existing shipping rules concerning the respective means of transportation.

13.3 After transportation under the conditions different to exploitation conditions the Detectors shall be ready to operate after a maximum of six hours.

13.4 During storage period lithium batteries should be removed from the holders or isolators should be installed.

Note – The storage premises should not contain any current-conducting dust, acid and alkali fumes, or corrosive or destroying insulation gases.

14 DISPOSAL INFORMATION

14.1 The Detector does not contain precious metals, hazardous or toxic substances that can harm human health or the environment, and does not pose a danger to life, human health and the environment at the end of its service life.

14.2 In this regard, the disposal of the Detector can be carried out according to the rules for the disposal of general industrial waste.

15 MANUFACTURER WARRANTY

15.1 LLC NPP RIELTA guarantees that the Detector meets the requirements of technical specifications within 39 months from the date of manufacture, subject to the conditions of transportation, storage, installation and operation.

15.2 Warranty period of operation of the Detector is 36 months from the date of commissioning within the warranty period of storage.

15.3 If during the warranty period the Detector, which is subject to the rules of transportation, installation and operation, is found to be inconsistent with the requirements of the technical specifications, it is to be replaced or repaired by the manufacturer.

Note – Lithium batteries are not covered by the warranty.

16 DATE OF MANUFACTURE

_____ month, year



ridom.ru

Made in Russia

v11