

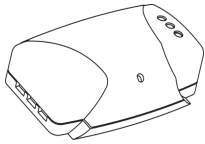

GLASS BREAK DETECTOR

«ZVON-1»



Installation Guide

1 Introduction

Glass break detector «Zvon-1» (hereinafter, the Detector) is designed to provide the following tasks performance:

- detecting destruction of construction glass: common and laminated with polymer film, installed in structural units (openings) and/or interior elements of closed spaces;
- generates alarm messages by alarm loop contacts opening;
- operation in condition of installation on wall, ceiling or on a pier between the monitored glass and curtains.

2 Specifications

Table 1

Parameter	Value
Maximal detection range, not less than	6 m
Minimal monitored area of:	
- a glass*	0.1 m ²
- a glass brick front surface with the sides length difference not exceeding 20 %	0.05 m ²
Power supply	9 ... 17 V DC
Warm up time	3 sec
Alarm message duration, not less than	2 sec
Operating temperature	minus 20 ... +45 °C
Permissible relative humidity at temperature 20 °C	90 %
IP rating	IP30
Consumption current, not more than	23 mA
Dimensions, not more than	80 x 47 x 29 mm
Mass, not more than	0.06 kg
Average service life, not less	8 years

* – Area of visible (opened) surface of a glass (glass unit), installed into a window frame

3 Informational Content

Table 2

Status	LED Indicator			Contacts
	Red	Yellow	Green	AL
«Norm»	OFF	OFF	OFF	Closed
«Alarm»	ON	*	*	Opened
«Switching ON»				
«Low Power Supply»				
«Interference on the 1-st Frequency»	*	ON	*	*
«Interference on the 2-nd Frequency»	*	*	ON	*
«Adjustment»	*	*	ON (at 1 Hz frequency)	*

* – without changes

4 Detection Zone Pattern

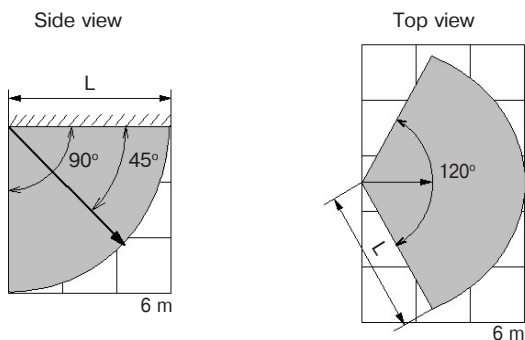

Figure 1

5 Choosing the Detector Location

Before installing the Detector, get acquainted with the following requirements:

- it is recommended to install the Detector at least 2 m height (see examples of installation in Figures 3 – 6);
- during joint operation with an active ultrasonic Detector, distance between Detectors must be not less than 1 m;
- the entire surface of the monitored glass should be available within the direct visibility of the Detector;
- distance (L) between the Detector and the farthest point of the monitored glass should not exceed 6 m;
- the Detector operation mode is set in accordance with Table 3.

Table 3

Jumper	Removed	Installed
SENS	Min	Max
MODE	Adjustment	Standby Mode
IND	OFF	ON

6 Installing the Detector

6.1 The Detector comprises cover and base (1) with installed printed circuit board (PCB) (3). Cover is fixed on a base by two lugs (8) and a latch (4). The base design includes openable holes (11) for wiring and a hole (2) for fastening a base to the mounting surface. PCB is fastened to the base by lugs (8) and latch (5).

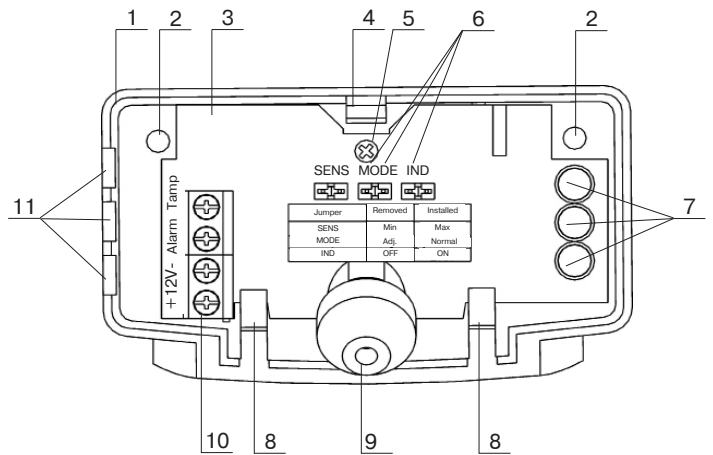

Figure 2 – The Detector without Cover

PCB comprises marked terminals (10) for connection with control panel, three LED indicators (7), microphone (9) and jumpers (6) for the Detector adjustment.

6.2 For the Detector installation act as follows:

- insert a flat screwdriver into the slot at the side wall of the cover, push the latch (4) and put off the cover;
- fasten the base with the PCB by the screw to the mounting surface at the chosen place of installation;
- open the necessary quantity of holes (11) in the sidewall of the base, insert and pull wires through them;
- connect the Detector to the control panel in accordance with its manual.

7 Switching ON and Adjustment

Install jumpers «MODE» and «IND», remove «SENS» jumper.

Energize the Detector. At this moment red LED indicator should light up for 3 sec and get out, what is indicating the Detector turnover to standby mode. If indication displays interferences presence, eliminate it cause if possible.

Fulfill the Detector adjustment as follows:

- remove the MODE jumper (mode «Adjustment»);
- suspend a steel ball 21 – 22 mm in diameter on a 35 cm long thread near the farthest part of the monitored glass, deflect it at an angle of 30 – 70° (see Table 4). Deliver a blow to the most distant place of the secured glass. If red indicator is not lighting after test blows, the Detector sensitivity should be increased by installation of SENS jumper;
- check adjustment correctness of the Detector with the closed cover.

Changeover of the Detector from «Adjustment» to «Standby» mode is fulfilled by MODE jumper installation (see Table 3) or in 15 min automatically.

For monitoring the Detector availability, it is allowed to use electronic glass break simulator during adjustment.

Table 4

Glass thickness, mm	<3	3...4	4...5	5...6	6...7	>7
Ball deflection angle for ordinary, armed and ornamental glass, °	30	35	40	45	50	55
Ball deflection angle for, hardened and laminated glass, °	45	50	55	60	65	70

8 Scope of Delivery

Each Detector unit package contains the items listed in Table 5.

Table 5

Name	QNT
Glass break Detector «Zvon-1»	1 pc.
Testing steel ball	*
Glass break Detector «Zvon-1». Installation Guide	1 copy
* – Supplied optionally	

9 Manufacturer's Guarantees

The manufacturer guarantees conformity of the Detector to the Technical Specifications requirements provided the transportation, storage, installation and operation conditions are observed.

The guaranteed shelf life of the Detector is 63 months since the date of manufacture.

The guaranteed useful life is 60 months since the day of putting into operation within the guaranteed shelf life.

The Detectors that are found non-conforming to the Technical Specifications requirements shall be repaired by manufacturer, provided the installation and operation rules have been complied with.

10 Storage and Transportation

The Detectors in their original packing may be shipped by any transport means in covered vehicles (in railway, cars, trucks, sealed heated compartments of aircraft, ship cargo holds, etc). The storage room should be free from current-conducting dust, acid vapors, alkali and gases that cause corrosion and destroy insulation.

11 Packing Certificate

Glass break detector «Zvon-1» has been manufactured in compliance with the active technical documentation and classified as fit for operation and packed by «Development and Production Enterprise RIELTA » LLC.

Packing date _____
month, year

Detector Installation Examples

Correct Detector installation options see Figures 3 – 6, the incorrect one – Figure 7.

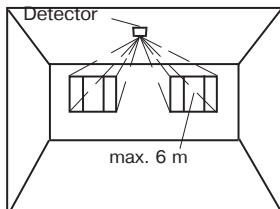

Figure 3 – Installing the Detector on the Ceiling

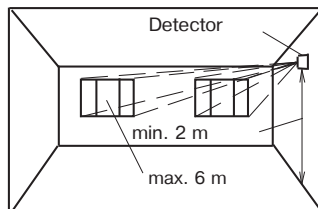

Figure 4 – Installing the Detector on a Side Wall

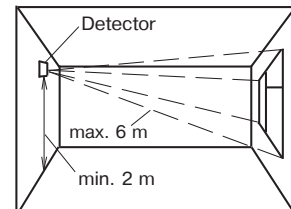

Figure 5 – Installing the Detector on the Opposite Wall

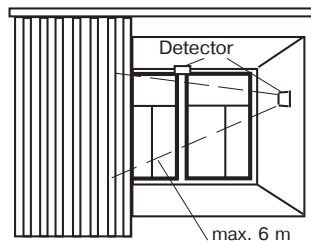

Figure 6 – Detector Installation between the Glass and the Curtains (Blinds) or on a Window Frame

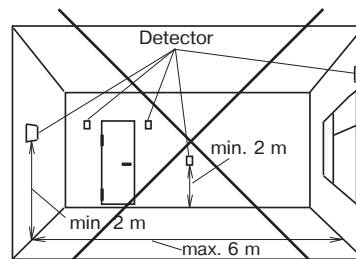

Figure 7 – Unauthorized Detector Installation Places