



## PASSIVE INFRARED DETECTOR WITH PET IMMUNITY

### «PYRONE-5»

#### Installation Guide

#### 1 Introduction

Passive infrared detector «Pyrone-5» (hereinafter, the Detector) is intended for detecting intrusion into a closed protected space and generating an alarm message by the relay contacts opening.

The Detector is resistant to the ambient light impact and radio interference.

The Detector ensures absence of false alarms caused by movement of pets with weight up to 40 kg if the Detector is installed at the height not less than 2,3 m.

The Detector is installed directly on a wall or in a corner of a room.

#### 2 Features of the Detector

- Dual-element pyrodetector;
- Spherical lens provides pet immunity as well as absence of distortions within the detection zone;
- Protection against ingress of insects to the pyrodetector;
- Microprocessor-based signal processing;
- LED indicator mode selection;
- Selection of the detection range and pet immunity (10, 20 or 40 kg pet weight);
- The Detector is powered from power supply unit with rated output voltage 12 V.

#### 3 Specifications

Table 1

Parameter	Value
Maximum detection range	not less than 10 m
Recommended installation height	2,3 m
Power supply, V DC	8 V... 30 V
Consumed current, not more	15 mA
Output relay contacts	Energized FormA (NC) relay 30mA, 40 V
Alarm message duration, not less than	2 s
Detection zones (DZ)	8 far zones, 4 nearby
Pet immunity	Is chosen by means of «1» and «2» DIP-switches in accordance with Table 3
Ambient class	Boreal Climate (background temperature 15 - 35 °C, relative humidity 25 - 75 %, air-pressure 86- 106 kPa)
Operating temperature	from minus 30 °C to +50 °C
IP rating	IP41
Dimensions, not more than	105x75x56 mm
Weight, not more than	100 g
Average service life, not less than	8 years

The Detector is designed to operate continuously around the clock.

The Detector interference protection provides absence of false alarms under the following conditions:

- pets movement (in accordance with Table 3);
- background illumination differential;
- convective air flows;
- slow background temperature changing;
- voltage impulses in power-supply circuit;
- electrostatic discharge;
- electromagnetic fields in FM band.

The Detector generates Alarm message under human movement within the detection zone limits transversally its side border at a speed range 0.3 – 3 m/s for the distance of 3 m. The Detector is resistant to:

- transport jolting with the acceleration 30 m/sec<sup>2</sup> with impact frequency from 10 to 120 impacts/sec or 15000 impacts with the same acceleration;
- the ambient temperature minus 50 ... +50 °C;
- relative air humidity (95 ± 3) % at the ambient temperature +35 °C.

After transportation under the conditions different to exploitation conditions the Detector shall be ready to operate after a maximum of six hours.

Average time between failures is not less than 60 000 hours.

#### 4 Scope of Delivery

Each Detector unit package contains the items listed in Table 2.

Table 2

Name	QNT
Passive infrared detector «Pyrone-5»	1 pc.
Passive infrared detector «Pyrone-5». Installation Guide	1 copy

#### 5 Field of Application

The Detector can be installed in apartments, as well as in shops, offices, museums and industrial facilities. The Detector may be installed in premises, that are inhabited by pets weighing up to 40 kg.

#### 6 Choosing an Installation Place

When choosing the Detector installation place, it is advisable to take note of the fact that the detection zone may be limited by non-transparent objects (curtains, houseplants, cabinets, bookcases, etc.), as well as glass and mesh partitions. There must be no windows, air conditioners, space heaters or heating radiators in the Detector visibility zone. The presence of furniture items on which an animal may climb in the detection zone may cause a false alarm.

Recommended installation height – 2,3 m from the floor.

The Detector should be installed far enough from power supply cables.

#### 7 Detection Pattern

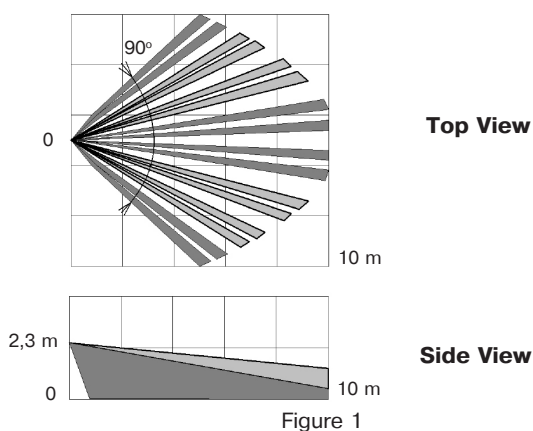

#### 8 Installation

Before installing the Detector, remove its cover and the PCB. For this purpose:

- remove the cover of the Detector;
- push up the holder and remove the printed circuit board (PCB) (See Figure 2);
- drill the holes (Figure 2) in the base of the Detector case. They will be used for wire installation and fastening the Detector.
- choose the installation place, mark out and drill the installation holes in the wall with regard for the position of the holes on the Detector base;

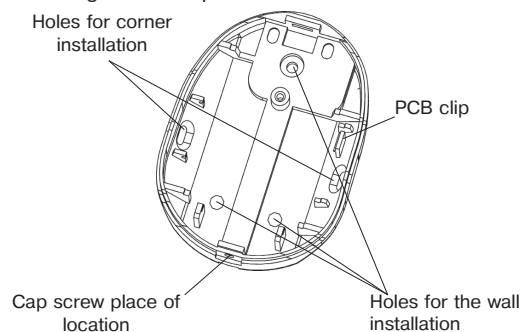

- fasten the base on the chosen place;
- install the PCB on its place;
- put on the cover.

**Note** – To exclude false alarms in the pet immunity mode, the Detector should be installed vertically.

#### 9 Connection

- Fulfill connections in accordance with designation on the PCB (See Figure 3).
- Set up DIP-switches in accordance with application conditions (DIP-switches assignment see on the PCB or in Cl.10 of this Installation Guide).
- Put on the Detector cover.

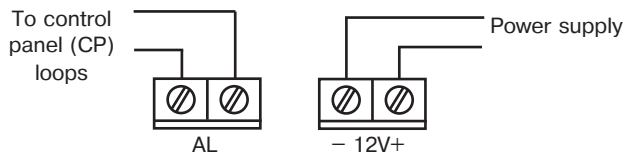

Figure 3

## 10 DIP-switches Setting

Table 3

DIP-switch		Pet immunity up to	Note
«1»	«2»		
OFF	OFF	10 kg	Cats and fancy breed dogs
OFF	ON	20 kg	Cats and small
ON	OFF	40 kg	Long-hair dogs (Temperature contrast 6°C)
ON	ON	40 kg	Any dogs weighting up to 40 kg (Temperature contrast 8°C)

## 11 Indication

Table 4

Message	LED indicator state
«Warm-up time»	Lighting for 40 s after energizing
«Norm»	Indication is OFF
«Alarm»	Lighting for 3 s

## 12 LED indication disabling

For the Detector operation masking the Detector provides LED indication disabling mode. Switching to the mode is fulfilled by setting up the DIP-switch «3» to «OFF» position.

## 13 Functional Testing

Before functional testing carrying out, close doors, windows, vents and switch off forced air supply. Wait for 60 – 70 s after Detector energizing. Determine the detection zone border by LED switching on.

Start walking across the detection zone at different distances from the Detector (including maximal range). After 3-4 steps across the detection zone, the Detector should display the detection by the LED switching on. Wait till the LED is switched OFF and continue walking across the detection zone. There must be no indication in absence of moving objects in the room.

**ATTENTION!** The Detector must be checked at least annually in order to test its performance

## 14 Storage and Transportation

The Detectors in their original packing may be shipped by any transport means in covered vehicles (in railway, cars, trucks, sealed heated compartments of aircraft, ship cargo holds, etc).

The storage room shall be free from current-conducting dust, acid vapors, alkali and gases that cause corrosion and destroy insulation.

## 15 Manufacturer's Guarantees

The Manufacturer guarantees conformity of the Detector to its Technical Specifications if conditions of transportation, storage, assembling and operation are observed. The guaranteed storage period is 63 months since the date of manufacturing the Detector.

The guaranteed period of operation is 60 months since the date of commissioning within the storage period guaranteed.

The Detectors that are found to non-conforming to their Technical Requirements shall be repaired by the Manufacturer, provided that the installation and operation rules have been complied with.

## 16 Acceptance and Packing Certificate

Passive infrared detector «Pyron-5» has been manufactured in compliance with the active technical documentation and classified as fit for operation and packed by «Development and Production Enterprise RIELTA » LLC.

Packing date \_\_\_\_\_  
month, year