

PASSIVE INFRARED WIDE ANGLE SECURITY DETECTOR FOR OPEN AREAS

«PYRONE-8»

Installation Guide

1 General Information

1.1 Outdoor passive infrared wide angle security detector for open areas «Pyrone-8» (hereinafter, the Detector) is intended to detect intrusion into the controlled indoor or outdoor spaces and to generate the «Alarm» signal.

1.2 The Detector is equipped with:

- two output relays: «AL» and «FAULT»;
- red LED indicator.

1.3 The Detector generates five types of signals:

- «Activation» – the signal is generated for the warm-up period after energizing;

- «Norm» – when no external influences are detected;
- «Alarm» – in case of intrusion into the controlled area;
- «Tampering» – under the case tampering;
- «Failure» – in case of voltage drop below the valid range.

1.4 The Detector features:

- pet immunity up to 20 kg within the detection range;
- immunity to background illumination drop up to 20 000 lx.

1.5 The Detector is resistant to electromagnetic interferences.

1.6 Industrial radio interference generated by detectors during operation does not exceed the rates established for residential spaces.

1.7 The Detector is designed for continuous operation outdoors.

2 Principal Technical Characteristics

The scope of delivery includes a swivel bracket (which provides control of the detection zone location) and a weather shield.

3 Specifications

Table 1

Parameter	Value
Maximum detection range:	
- at mounting height 2-2.5 m	12 m
- at mounting height 2.5-3 m	10 m
Minimum detection range	1.5 m
Speed detection range	0.3...3 m/sec
Detection field-of-view angle in horizontal plane	90°
Duration of the «Alarm» signal, min	2 sec
Voltage range	from 9 to 30 V
Current consumption, max	20 mA
Operating temperature	minus 40...+50 °C
Permissible operating range for output contacts, max	40 V 30 mA
Permissible relative humidity at 25 °C,	app to 100 %
Climatic design	moderately cold climate
Ambient class	Boreal Climate(background temperature 15-35 °C, relative humidity 25-75 %, air-pressure 86-106 kPa)
IP rating	IP54
Dimensions , max	180x70x60 mm
Weight, max	0,2 kg

4 Scope of Delivery

Table 2

Description and designation	Qnt
Passive infrared wide ngle security detector for open areas «Pyrone-8»	1 pc.
Swivel bracket	1 pc.
Nylon wall plug NAT 5x25 SORMAT	2 pcs.
Screw 3-3x30.016	2 pcs.
Cable gland PG7	1 pc.
Weather shield	1 pc.
Plastic sealer	1,0±0,5 g
Passive infrared wide ngle security detector for open areas «Pyrone-8». Installation Guide	1 copy

5 Mounting and Assembling

5.1 The Detector (Figure 1) consists of base (3), PCB (4) and cover (7). Swivel bracket (1) and weather shield (2) are available. The cover is fixed to the base by four screws (8) with a sealing gasket. The PCB is fixed on the base by means of latch (11) and screw (6). Before mounting the detector the cover and the PCB should be separated from the base.

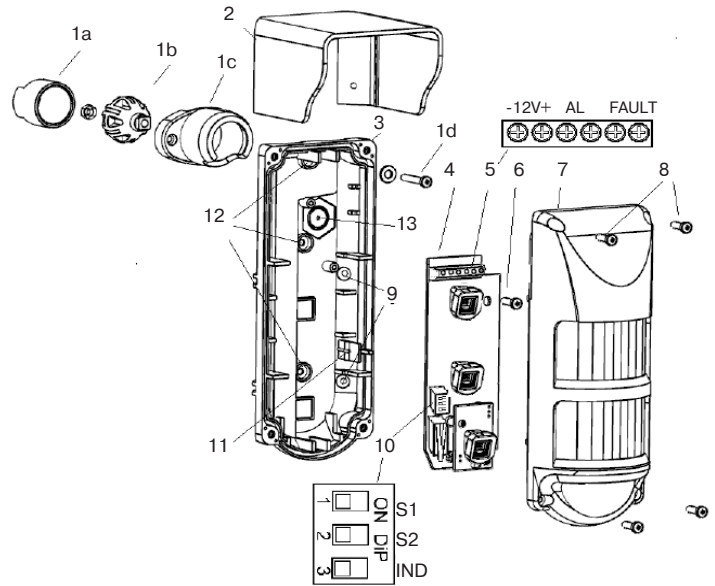

Figure 1 - The Detector Layout

- 1 - swivel bracket (1a - bushing, 1b - sphere, 1c – swivel bracket base, 1d - screw);
- 2 - weather shield;
- 3 - base;
- 4 - PCB;
- 5 - wiring terminals;
- 6 - screw for fixing the PCB;
- 7 - cover;
- 8 - screw for fixing the cover;
- 9 - openable holes for installation in the corner;
- 10 - switch;
- 11 - latch;
- 12 - openable holes for securing the support frame;
- 13 - openable hole for the cable gland.

5.2 It should be taken into consideration that the detection zone may be limited by non-transparent and semi-transparent objects such as meshed fences, glazed structures etc. The detection zone should be free from moving objects (tree branches, bushes etc).

5.3 Before mounting the detector the swivel bracket should be assembled as follows:

- insert the nut into the sphere recess (1b);
- insert sphere (1b) and then bushing (1a) into swivel bracket base (1c).

5.4 The assembled swivel bracket should be screwed to the wall (or ceiling) in the place of mounting the detector. The swivel bracket base may be used as a template for marking out fixing holes in the mounting surface.

5.5 Open hole (13) in the base for fixing the cable gland PG7 to the base and hole (12) for installation of the detector to the swivel bracket.

5.6 Mount cable gland PG7, pull all necessary wires through this gland into the detector case and tighten the coupling nut of the cable gland for hermetic encapsulation providing.

To maintain tightness in the cable gland is permissible to fix the cable with an outer diameter of 3.5-6.5 mm.

5.7 Fasten the base to the mounted swivel bracket by the screw (1d).

5.8 After fastening the base on the support frame seal the hole for screw (1d) with plastic sealer supplied.

5.9 Mount the PCB and fix it with latch (11) and screw (6).

Attention! When mounting the PCB, align the slot of the PCB with the mark on latch (11).

5.10 Connect the detector to the control panel (CP) following the instructions of the CP Datasheet. Marked terminals (5) for connection of the detector to CP are arranged in the upper part of the PCB.

6 Activation and Testing

Table 3

Signal	State of contacts		Indication	Duration
	AL	FAULT		
Activation	Open	Open	Intermitt. 1 Hz	60 sec
Norm	Closed	Closed	Switched off	
Alarm	Open	Closed	Switched on	2 sec
Failure	Open	Open	Intermitt. 5 Hz	15 min
Tampering	Closed	Open	No influence	

After energizing the detector performs self-testing during 1 min («Activation» signal) and then it is transfers to the standby mode. After changing to standby mode the detector is able to generate the «Alarm» signal.

When voltage drops to the level of $8_{-0,5}V$, the detector generates the «Failure» signal. The duration of this signal is 15 min after elimination of the failure.

Tampering the detector case results in the «Tampering» signal generation.

For the diagram of the detection zone of the detector see Figure 2.

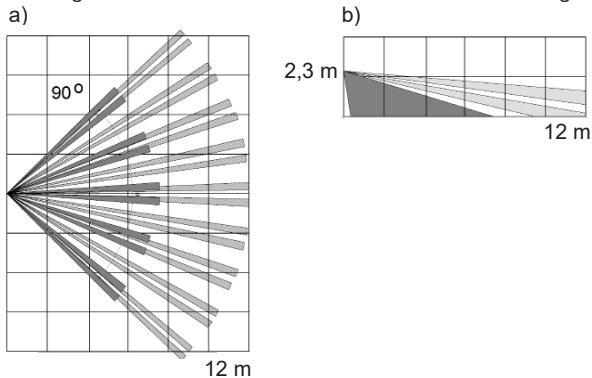

Figure 2 – Detection pattern
a) top view b) side view

To determine the limits of the detection zone, start movement across the detection zone at a speed of 0,5 - 1 m/sec 60 sec after activation of the detector. Detection of movement is displayed by the red indicator lighting.

7 Adjustment

7.1 After assembling and installation, set switches «S1», «S2», «IND» (Figure 1, pos. 10) to «ON» position, replace the cover and perform test activation of the detector.

7.2 Adjustment of the detector includes the following: the detection zone position setting, selection of sensitivity and indication mode setting.

The position of the detection zone is changed by rotating of the detector on the swivel bracket.

Sensitivity of the detector is selected by block of DIP-switches «S1» - «S2» (10) (see Figure 1).

Generation of the «Alarm» signal in the absence of movement within the the detection zone limits shows severe interference conditions.

Switch		Sensitivity	
S1	S2		
off	off	1	min
off	on	2	↓
on	off	3	
on	on	4	

In this case it is recommended to narrow the sensitivity of the detector by switches «S1» and «S2». Sensitivity of the detector adjusted to minimal value reduces maximal operation range of the detector up to 8 m.

After changing sensitivity, check the detection zone limits.

Indication of the «Alarm» signal can be disabled by setting switch IND in position «OFF». Indication of «Activation» and «Failure» signals does not depend on the position of switch «IND».

Attention! The detector should be tested for availability not less than once a year.

8 Storage and Transportation

8.1 The storage room should be free from current-conducting dust, acid vapors, alkali and gases that cause corrosion and destroy insulation.

8.2 Detectors packed for shipping should be stored no more than 3 months. The shipping package shall be free from leaks and dirt.

8.3 In case of storage over 3 months detectors should be unpacked.

8.4 Factory-packed detectors can be shipped by any transport means in covered vehicles (in railway cars, trucks, sealed heated compartments of aircraft, holds etc).

9 Manufacturer's Guarantees

9.1 The Manufacturer guarantees conformity of the detector to the requirements of specification provided that conditions of transportation, storage, assembling and operation are observed.

The guaranteed storage period is 27 months since the date of manufacturing the detector.

9.2 The guaranteed period of operation is 24 months since the date of commissioning within the storage period guaranteed.

9.3 If non-conformity of the detector to technical requirements is detected during the guaranteed period provided that rules of operation are observed it shall be repaired by the Manufacturer.

10 Acceptance and Packing Certificate

Passive infrared detector «Pyrone-8» has been manufactured in compliance with the active technical documentation and classified as fit for operation and packed by «Development and Production Enterprise RIELTA» LLC.

Packing date _____
month, year