

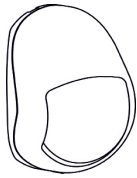

**WIRELESS PASSIVE  
INFRARED DETECTOR WITH  
PET IMMUNITY  
«Pyrone-5RK»**



**Installation Guide**

**1 General Information**

1.1 Wireless passive infrared detector «Pyrone-5RK» (hereinafter, the Detector) is intended for detecting intrusion into a closed protected space, generating an alarm message and its transmission via a two-way wireless channel within the 433.05 – 434.79 MHz frequency range according to «Rielta-Contact-R» wireless two-way data exchange protocol.

The Detector is intended to operate as a component of a system that is operated by any control panel (hereinafter, CP) supporting «Rielta-Contact-R» wireless two-way data exchange protocol.

1.2 The Detector powered by one power supply lithium CR123A.

1.3 The Detector comprises two-color (green and red) LED indicator, which is intended for the Detector operability monitoring. The possibility of indicator disabling is provided.

1.4 The Detector is equipped with a jumper for sensitivity adjustment and «RESET» contacts for the Detector changeover to «Binding» mode.

1.5 The Detector ensures generation and transmission via radio communication the following messages:

- normal state message;
- alarm message;
- tamper message;
- power-supply low-battery message;
- «Binding» mode operation indication;
- «Identification» mode indication;
- communication quality indication.

1.6 Radio communication is initiated by the Detectors at 10, 15, 30 sec, 1, 2, 5, 10 min intervals assigned in the process of the Detector adjustment. Alarm and tamper messages are transmitted immediately.

1.7 The Detectors are designed to operate continuously, around the clock.

1.8 The Detectors have immunity to electromagnetic interference.

**2 Features of the Detector**

- Dual-element pyrodetector.
- Distortions prevention in the detection zone by means of spherical lens.
- Pet immunity.
- Protection against ingress of insects to the pyrodetector.
- Pet immunity adjustment.
- Automatic switching to a backup operating frequency in case of an imperfect interference situation on the main one.

**3 Field of Application**

The Detector can be installed in apartments, as well as in shops, offices, museums and industrial facilities. The Detector may be installed in premises, that are inhabited by pets weighing up to 40 kg (20 kg).

**4 Specifications**

Table 1

Parameter	Value
Detection zones	8 long-range zones, 4 short-range zones
Maximum detection range, m	10
Detected speed range, m/sec	0.3 ... 3
Operating temperature	from minus 20 °C ... +55 °C
Permissible relative humidity at +25 °C, %	98
Ambient class	Boreal climate
IP Rating	IP41
Dimensions, not more, mm	105 x 75 x 56
Weight, not more, kg	0.1
The duration of operation of the detector with a set radio exchange period of 60 seconds or more, normal climatic conditions and disabled indication	up to 8 years
Average service life, years	8

**5 Scope of Delivery**

Table 2

Name	QNT.
Wireless passive infrared detector «Pyrone-5RK»	1 pc.
Swivel bracket	*
Lithium power supply battery CR123A	1 pc.**
Wireless passive infrared detector «Pyrone-5RK». Installation Guide	1 copy
* Supplied optionally	
** Installed	

**6 Detection Zone Diagram**

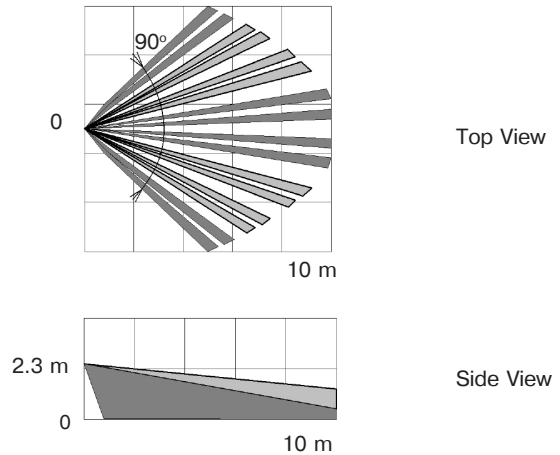

Figure 1 - Detection zone diagram

**7 Binding with the CP**

The Binding procedure is intended for logging of the Detector in the CP and transmission of service information to it.

7.1 Prepare the CP for the Detector logging in accordance to the CP manual.

7.2 Install the PCB into the Detector case, and then install the CR123A power-supply battery or remove the isolation.

7.3 Blinking of the LED indicator green displays the Detector readiness for the binding procedure.

7.4 In case the LED indicator does not blink, close the «Reset» contacts for a short period.

7.5 After a successful binding with the CP, the LED indicator lights red for 2-3 sec.

7.6 The «Binding» procedure is limited to 100 sec. After it expires, the Detector switches to the sleep mode. To resume the «Binding» mode, the «Reset» contacts should be temporary closed.

**8 LED Indication**

Table 3

Detector status	Status of indicators	Operating mode
completion of Mode «Binding»	turning on the red indicator light for 2–3 seconds	
«Binding» mode	intermittent switching on of the green indicator light	registration of the detector in the CP
«Recognition» indication	alternately turning on the red and green light indicators for 15 minutes or until the case is opened	the corresponding command was received from the CP
«Alarm»	one-time switching on of the red indicator light with a period of 4 seconds *	the status indication is on and the «Recognition» indication is off
Communication quality assessment	check out the section «Communication quality assessment»	

\* Light indication of the status of the detector — turns on and remains in the first 15 minutes after closing the case in the absence of other types of indication, provided that during this time a notification of unauthorized access will not be generated or a command from the control panel to prohibit the indication will not be transmitted

## 9 Choosing an Installation Place for the Detector

The Detector must be located in the radio-coverage zone of its CP. Therefore, it is advisable to appraise quality of communication beforehand. The procedure of communication quality appraising is described in the chapter «Communication Quality Appraising».

When choosing the Detector installation place, it is advisable to take note of the fact that the detection zone may be limited by non-transparent objects (curtains, houseplants, cabinets, bookcases, etc.), as well as glass and mesh partitions. There must be no windows, air conditioners, space heaters or heating radiators in the Detector visibility zone. The presence of furniture items on which an animal may climb in the detection zone may cause a false alarm.

Recommended installation height — 2.3 m from the floor.

The Detector should be installed at least 0.5 m distance from electric cables.

## 10 Communication Quality Appraising

10.1 Before installing the Detector to its place of operation, it is advisable to appraise the CP communication quality as follows.

- Prepare the Detector for operation and put it on its location place with a closed cover;
- open the Detector case.

10.2 The detector will generate a tamper notification, transmit it via radio channel and indicate the quality of CP communication in accordance with Table 4.

Table 4

LED Indication	Communication Quality Appraisal	Recommendations
LED indicator blinks green three times	Excellent	Install the Detector at this place
LED indicator blinks green two times	Good	
LED indicator blinks green one time	Communication established	Use «Ladoga-RK» system repeater
LED indicator blinks red four times	No communication	

## 11 Installing the Detector

Before installing the Detector, remove its cover and the PCB. For this purpose:

- remove the cover of the Detector;
- remove the printed circuit board by pressing the retaining clip (see figure 2);
- drill holes in the base of the housing (see Figure 2), which will be used to mount the detector;
- after selecting the installation location, make a marking for installation taking into account the position of the holes on the base of the detector, drill holes in the wall;
- fix the base of the detector at the selected location;
- install the printed circuit board in place;
- close the lid.

**Note** — To exclude false alarms in the pet immunity mode, the Detector should be installed vertically.

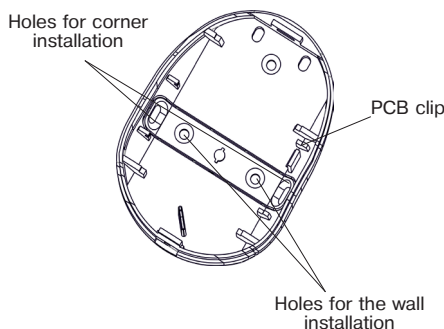

Figure 2 – The Detector base

## 12 Functional Testing

In presence of the pets weighing up to 40 kg in the room, remove the «10 kg» jumper, in presence of the pets weighing less than 10 kg in the room, install the «10 kg» jumper.

It is advisable to remove the «10 kg» jumper in the premises with a high interference level.

Start walking across the detection zone. After 3–4 steps across the detection zone, the Detector should display the detection by the LED indicator red blink. Wait for 10 sec and continue walking across the detection zone. There must be no indication in absence of moving objects in the room.

## 13 Detector Behavior

13.1 The Detector is powered on and off by installation and removal of the main power-supply battery.

13.2 In case of loss of communication with the CP, the detector continues to search for the CP. When turning off the CP for a long time, it is recommended to turn off the power of the detector (see clause 13.1).

13.3 It should be borne in mind that when operating the detector in the temperature range from minus 20 °C to +5 °C, the battery life may be less than 8 years.

**ATTENTION!** The Detector must be checked at least annually in order to test its performance.

## 14 Storage and Transportation

14.1 The Detectors in their original packing may be shipped by any transport means in covered vehicles (in railway, cars, trucks, sealed heated compartments of aircraft, ship cargo holds, etc). The Detector is resistant to:

- transport jolting with the acceleration 30 m/sec<sup>2</sup> with impact frequency from 10 to 120 impacts/sec or 15000 impacts with the same acceleration;
- the ambient temperature minus 50 ... +50 °C;
- relative air humidity (95 ± 3) % at the ambient temperature +35 °C.

14.2 After transportation under the conditions different to exploitation conditions the Detector shall be ready to operate after a maximum of six hours.

14.3 The storage room shall be free from current-conducting dust, acid vapors, alkali and gases that cause corrosion and destroy insulation.

14.4 When storing the detector, the lithium battery must be removed from the holder or an insulator must be installed between the «+» contact of the battery and the holder.

## 15 Manufacturer's Guarantees

15.1 The Manufacturer guarantees conformity of the Detector to its Technical Specifications if conditions of transportation, storage, assembling and operation are observed. The guaranteed storage period is 63 months since the date of manufacturing the Detector.

15.2 The guaranteed period of operation is 60 months since the date of commissioning within the storage period guaranteed.

15.3 The Detectors that are found to non-conforming to their Technical Requirements shall be repaired by the Manufacturer, provided that the installation and operation rules have been complied with.

**Note** — Warranty obligations are not applied to the power-supply battery.

## 16 Acceptance and Packing Certificate

Wireless passive infrared detector «Pyron-5RK» manufactured in accordance with current technical documentation is classified as fit for operation and is packed by «Development and Production Enterprise RIELTA» LLC.

Packing date \_\_\_\_\_  
month, year