



«Pyrone-4D» version 1

Installation Guide

1 Introduction

Passive infrared detector «Pyrone-4D» version 1 (hereinafter, the Detector) is designed for detecting intrusion into a closed protected area and generating an alarm message by the output relay contacts opening.

The Detector is resistant to the ambient light impact and radio interference.

The Detector is resistant to the interference of small animals (mice, rats, birds) in cells provided that the distance to them is not less than 2.5 m.

2 Features of the Detector

- Dual-element pyrodetector.
- Spherical lens.
- Microprocessor-based signal processing.
- Mounting height range – (2.3 ± 0.1) m.
- Sensitivity adjustment.
- Case tampering.

3 Specifications

Table 1

Parameter	Value
Maximum detection range	up to 15 m
Power supply	8 – 30 V DC, current 12 mA
Relay output contacts	NC 30 mA, 40 V
Alarm message duration	not less than 2 sec
Detection zones	Wide angle, 9 long-range zones, 5 short-range zones
Recommended installation height	(2.3 ± 0.1) m
Ambient class	Boreal climate
Operating temperature	minus 30 °C ... +55 °C
Permissible air humidity at +25 °C, without moisture condensation	98 %
IP rating	IP41
Dimensions, maximum	90 x 60 x 50 mm
Weight, maximum	60 g
Average service life	8 years

Detection zone layout is shown in Figure 1.

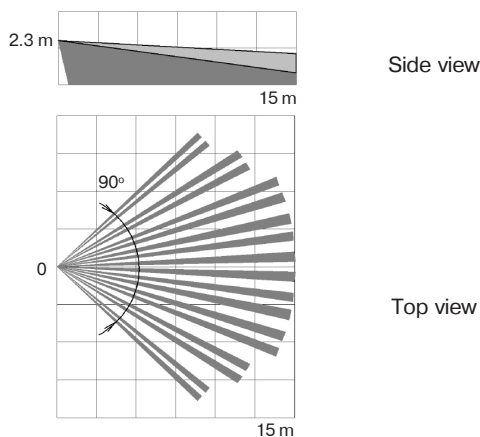

Figure 1 – Detection Zone Layout

The Detector is designed to operate continuously around the clock.

The Detector interference protection provides absence of false alarms under the influence of small animals movement, background illumination differentials, convective air flows, slow temperature changes, voltage impulses via power supply circuit, electrostatic discharge, FM-band electromagnetic fields.

The Detector provides no interferences to other comparable detectors, detectors of the other type and designation, as well as to any domestic radio equipment.

The Detectors in their original packing may be shipped by any transport means in covered vehicles (in railway, cars, trucks, sealed heated compartments of aircraft, ship cargo holds, etc.).

The Detector is resistant to:

- transport jolting with the acceleration 30 m/sec² with impact frequency from 10 to 120 impacts/sec or 15000 impacts with the same acceleration;
- the ambient temperature minus 50 ... +50 °C;
- relative air humidity (95 ± 3) % at ambient temperature +35 °C.

After transportation under the conditions different to exploitation conditions the Detector shall be ready to operate after a maximum of 6 hours.

The Detector ensures safe operation under voltage changing at it's terminals within the range 8 ... 30 V.

The Detector mean time to failure in standby mode is not less than 60 000 hours.

4 Scope of Delivery

Each Detector unit package contains the items listed in Table 2.

Table 2

Name	QNT
Passive infrared detector «Pyrone-4D» version 1	1 pc.
Swivel bracket	1 pc.*
Passive infrared detector «Pyrone-4D» version 1. Installation Guide	1 copy
* – supplied optionally	

5 LED Indication

Red LED indicator located on the front cover is used for the Detector state representation in accordance with Table 3.

Table 3

Message	LED indication state
«Warm-up time»	Indication is ON till the moment of the Detector readiness
«Norm»	Indication is OFF
«Alarm»	LED indicator is lighting for 3 sec

6 Choosing an Installation Place for the Detector

The Detector is intended for usage in closed premises.

When choosing the Detector installation place, it is advisable to take note of the fact that the detection zone may be limited by non-transparent objects (curtains, houseplants, cabinets, bookcases, etc.), as well as glass and mesh partitions. There must be no windows, air conditioners, space heaters or heating radiators in the Detector visibility zone.

Alarm loop and power supply wires should be located far enough from the powerful supply cables.

7 Installing the Detector

- Push the lock by a screw-driver through the hole on the lower side of the Detector base (See Figure 2) and put off the cover.
- In case of the Detector installation without swivel bracket put off the printed circuit board (PCB) by pushing the PCB locating pin.
- Drill the holes in base for wire installation and fastening of the Detector.
- Choose the installation place, mark out and drill the installation holes in the place of the Detector location with regard to the position of the holes in the Detector base (swivel bracket).
- Insert the wire through the holes in the Detector, leave several centimeters of the mounting wire for plugging to leading-in socket.
- Mount the wire in accordance with Figure 3.
- Fasten the base on the chosen place of installation.
- Put the PCB on it's place (if it was put off).
- Put on the cover.

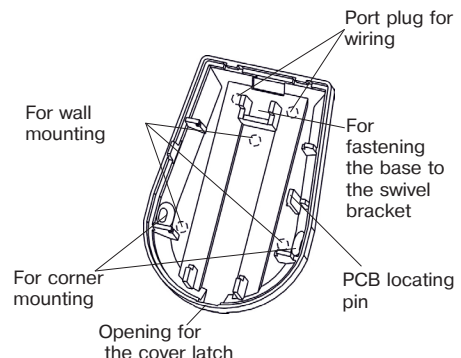

Figure 2 – Base

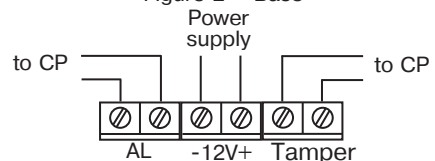

Figure 3

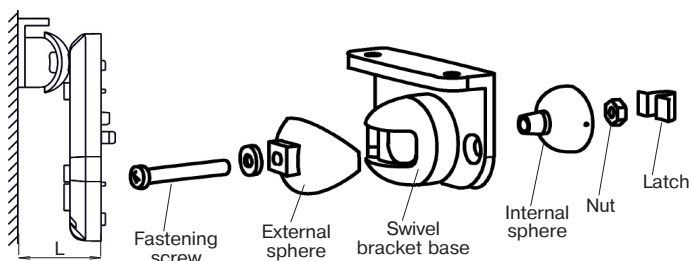

Figure 4 – Swivel bracket assembly and mounting

Note – In case of mounting the Detector on the swivel bracket, back off the M3x20 screw out of the swivel bracket. Holding the swivel bracket in assembled condition, insert the bulge into the external sphere corresponding recess and fasten with the screw. Apply force providing the base rotational motion on the swivel bracket.

Turn the Detector base first in left and then in right end points and fasten the swivel bracket on the installation place. Adjust the Detector base operation position and fasten the base by the M3x20 screw.

8 Sensitivity adjustment

The Detector comprises SENS jumper. With SENS jumper removed, the Detector operates in normal sensitivity mode. In this case the detection range is reduced up to 12 m. If the jumper is installed, the Detector operates in high sensitivity mode (maximum detection range is 18 m).

9 Functional Testing

After Detector energizing, wait for 60 – 70 sec before starting functional testing.

Determine the border of the detection zone by LED indicator switching ON.

Start walking across the detection zone. After 3 – 5 steps across the detection zone, the Detector should generate an alarm message and display the detection by the LED indicator switching ON. Wait until the LED indicator is OFF and continue walking across the detection zone. There must be no indication in absence of moving objects in the room.

ATTENTION! The Detector must be checked at least annually in order to test it's performance.

10 Storage and Transportation

The Detectors in their original packing may be shipped by any transport means in covered vehicles (in railway, cars, trucks, sealed heated compartments of aircraft, ship cargo holds, etc.) over any distances in compliance with the existing shipping rules concerning the respective means of transportation.

The storage premises should not contain any current-conducting dust, acid and alkali fumes, or corrosive or destroying insulation gases.

11 Manufacturer's Guarantees

The Manufacturer guarantees conformity of the Detector to it's Technical Specifications if conditions of transportation, storage, assembling and operation are observed. The guaranteed storage period is 63 months since the date of manufacturing the Detector.

The guaranteed period of operation is 60 months since the date of commissioning within the storage period guaranteed.

The Detectors that are found to non-conforming to their Technical Requirements shall be repaired by the Manufacturer, provided that the installation and operation rules have been complied with.

12 Acceptance and Packing Certificate

Passive infrared detector «Pyrone-4D» version 1 has been manufactured in compliance with the active technical documentation and classified as fit for operation and packed by «Development and Production Enterprise RIELTA » LLC.

Packing date _____
month, year