

Installation Guide
1 General Information

The seismic vibration detector «SH-V-10» (hereinafter, the detector) is designed for operation in a closed areas. The detector comprises signal processor module (SPM) and several (up to 10) sensors.

Depending on the number of plugged-in sensors to SPM, the seismic vibration detector controls from 1 up to 10 zones providing detection attempts to destroy concrete walls and floors with the thickness not less than 0.12 m, brick walls with the thickness not less than 0.15 m, wooden structures with the thickness from 20 up to 40 mm, plywood with the thickness not less than 4 mm, wood chipboard with the thickness not less than 15 mm, standard metal cabinets, ATMs, deposit safes, vault doors, free standing safes and other objects with a solid structure.

The unit provides immunity to acoustic noises, accidental impacts with monitored structure, prolonged vibration induced by transport facilities, lifts, ventilation systems, water supply systems, to electromagnetic interferences, electrostatic discharges and supply voltage jumps.

The detector is supplied by DC 12 V supply unit. Output signal is by Energized Form A (NC) SPM relay.

Consumption current:

- in standby mode up to 50 mA
- in malfunction mode up to 75 mA

The detector ensures control:

- cover tampers of the signal processing unit (SPM) and sensors covers;
- two-wired loop failure control;
- sensors disconnecting/failure.

Operating temperature range minus 30 ... +50 °C.

2 Installation

The detector installation examples are shown in Figure 1, where SPM – signal processor module, A1...An – sensors; G1 – supply unit; R1, R2 – control panel terminal resistors (EOL), CB – communication bus, AL – alarm loop, CP/CS – Control panel/Central station.

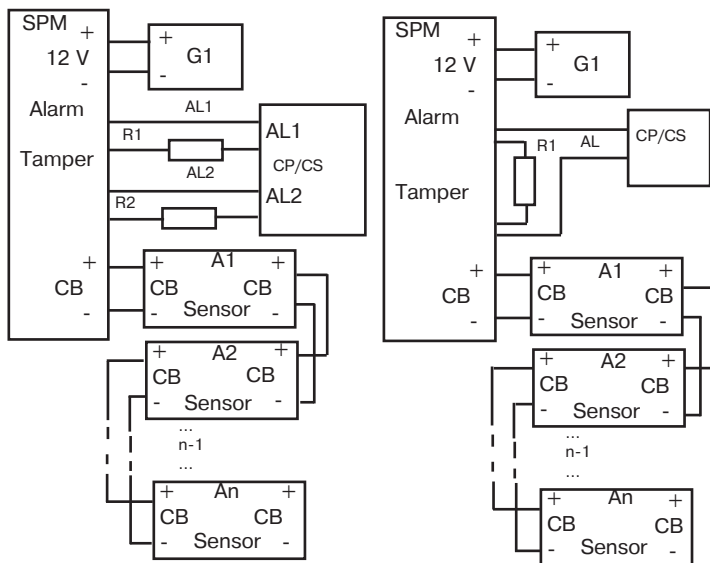

Figure 1

Wiring of power line and alarm loop is recommended by means of indoor signal cable 2 x 0.40, 4 x 0.40 or 6 x 0.40.

Electrical connection of connecting communication bus of SPM unit with the sensors is recommended by means of any signal shielded-type cable 2 x 0.4 with connecting the cable shield to of SPM loop «minus».

3 Mounting

The detector mounting examples are shown in Figures 2 – 8, where A1 ... An – sensors, L – radius (sensor detection range).

The detector is able to ensure control of the whole surface inside the protected premises or selected areas exposed to destroying attempts.

It is acceptable to use the detector for providing basic coverage of the monitored surface (Figure 2), or in case of cabinets, ATMs, Deposit Safes protection (Figure 3) – as an overall coverage including coverage of nearby surfaces (Figure 4).

It is possible to mount single or several sensors in one premise or at a single structure.

The sensors mounting on the different types of structures is realized as follows:

- for brick or concrete walls – by means of anchors;
- for wooden structures (Figures 5, 6) – by means of wood screws or self-driving screws;
- for metal safe, vault door, cover of the ATM block (Figure 7) – by means of 2 screws (4 mm, 15 mm length);
- for armored safe (Figure 8) – by means of any type of superglue.

In order to choose the place for SPM mounting it is necessary to take into account, that the communication bus connecting SPM to sensors must not exceed 50 m and the SPM LED indication must be visible while arming the object.

If the number of sensors switched to SPM is less than 10, the length of the communication bus can be increased up to 2.5 m for each unused sensor, but it's total length must not exceed 72 m.

The SPM mounting is executed in the same way as the detectors.

4 DIP-Switches

Table 1

Switch symbol	DIP-switch sequence number	Mode	DIP-switch position	
			ON	OFF
TEST	1	Testing mode	Switched ON (in accordance with Table 2)	-
MEM	2	Event memory indication	Event indication switched on till switching off the power	Event indication switched on during alarm
IND	3	Indication	Switched ON	Switched OFF
SNC	4	Control of plugged-in sensors quantity	Switched ON	Switched OFF

Notes

1 The number of sensors switched to SPM is saved to nonvolatile memory after DIP-switch transfer from «ON» to «OFF» position.

2 After removal the cause of alarm signals (voltage failure, SPM – sensor communication bus failure or non-conformance of the number of switched sensors), the LED changes from red to yellow and keeps lighting until DIP-switch is transferred to «OFF» position.

The supervision of test mode is executed as shown in Table 2.

Table 2

Sequence number of the DIP-switch «1» shifting to «ON» position	Test mode number (Groups of monitored structures)	Yellow LED lighting
1 («OFF» ⇒ «ON»)	I (metal cabinet, ATM, safe, vault door)	Infrequent blinking (2 times per second)
2 («OFF» ⇒ «ON» ⇒ «OFF» ⇒ «ON»)	II (wooden, plywood, wood chipboard surfaces)	Frequent blinking (10 times per second)
3 («OFF» ⇒ «ON» ⇒ «OFF» ⇒ «ON» ⇒ «OFF» ⇒ «ON»)	III (a brick or concrete building structure)	Continuous lighting

5 Detector adjustment

5.1 Transfer SPM DIP-switches «2» and «3» to «ON» position.

Put off covers of all plugged-in sensors, set the jumper «ADJ» to the PCB, turn the regulator «SENS» clockwise to the stop (maximum level of sensitivity). In this mode tamper is switched off. Switch the detector on, thereby all SPM LEDs will light up once and then go out. A «NORM» signal is accompanied by relay contacts closing.

A lighted Green LED indicates a relatively high level of vibration interference in the monitored structure. Eliminate the source of interference.

Red LED blinking for 2 times per second indicates that there is a power supply malfunction – supply voltage is less than permissible. Correct the malfunction.

Red LED blinking for 10 times per second indicates the SPM – sensors communication bus failure, sensor disconnection or non-conformance of a number of the wired sensors to the number sensors logged in nonvolatile memory (if the DIP-switch «4» is set in «ON» position). Correct the failure.

Turn the regulator «SENS» at all wired sensors counter clockwise to the stop (minimum level of sensor sensitivity).

5.2 For the adjustment of the sensor mounted on metal cabinet, ATM, safe, or vault door:

- switch the detector on;
- turn the SPM DIP-switch «1» from «OFF» to «ON» position (set the I test mode)*. Thereby the yellow LED must change to a mode of blinking (2 times per second);
- to produce test signals, apply the steel plate to the detected surface at maximal distance from the sensor and fulfill cycles of drilling several holes in depth 2 ... 3 mm increasing the sensitivity of the sensor till getting response of the SPM green LED after each drilling, and red LED response after each third drilling.

5.3 For the adjustment of the sensor mounted on wooden, plywood, wood chipboard surfaces:

- switch the detector on;
- turn the SPM DIP-switch «1» to the following positions: «OFF» ⇒ «ON»

⇒ «OFF» ⇒ «ON» (set the II test mode)*. Thereby the yellow LED light must change to a mode of blinking (10 times per second);
 - to produce test signals, apply the cant timber to any place at the boundary of the monitored area and fulfill three cycles of handsaw cutting of the timber with the forcing causing the destruction of the material, increasing the sensitivity of the sensor till getting response of the SPM green LED after each handsaw cutting, and red LED response after each third handsaw cutting.

5.4 For adjustment of the sensor mounted on a brick or concrete building structure:

- switch the detector on;
- turn the SPM DIP-switch «1» in «OFF» ⇒ «ON» ⇒ «OFF» ⇒ «ON» ⇒ «OFF» ⇒ «ON» position (set the test mode III)*. The yellow LED light must change to a mode of continuous lighting;
- place a «textolite» plate against the structure at any location at the boundary of the monitored area;
- to produce test signals, make series of impacts to the plate with a hammer (simulation the destruction attack). After each strike increase the sensitivity level of the sensor till getting of the SPM green LED response after each first strike, and red LED response after each third strike.

5.5 The same tactics in sensors adjustment is applied for ATM front panel protection against vandalism.

5.6 After the end of adjustment remove all the jumpers from the sensors print-boards, put on covers to all wired sensors and SPM. Turn all the DIP-switches to the position (SeeTable 2) in accordance with chosen protection tactics of the object.

* The exit from TEST mode is ensured by means of turning DIP-switch «1» to «OFF» position, or it goes on automatically after 30 min.

6 Manufacturer's Guarantees

The guaranteed useful life of the detector is 60 months since the day of putting into operation within the guaranteed shelf life. If failures or malfunctions of this product occur during warranty period under the observance of exploitation and installation rules shall be repaired by the manufacturer.

7 Packing Certificate

The seismic vibration detector «SH-V-10» has been manufactured in compliance with the active technical documentation and classified as fit for operation and packed by «Development and Production Enterprise RIELTA» LLC.

Packing date _____
 month, year

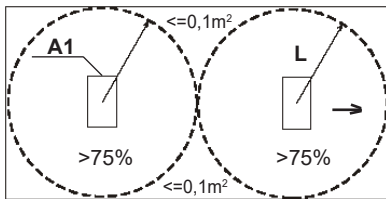

Figure 2 - Monitoring a basic part of an object (>75%)

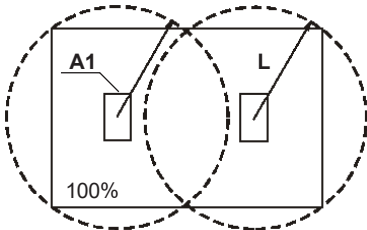

Figure 3 - Total monitoring of an object (100%)

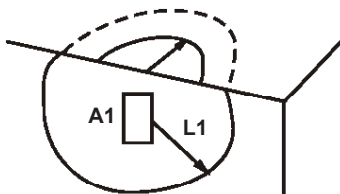

Figure 4 - Monitoring an adjacent structure

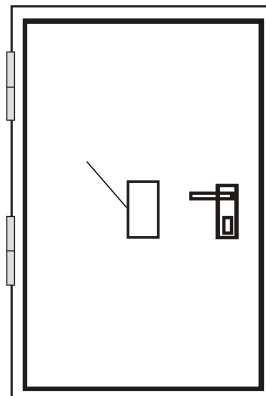

Figure 5 - Monitoring a hollow wooden door

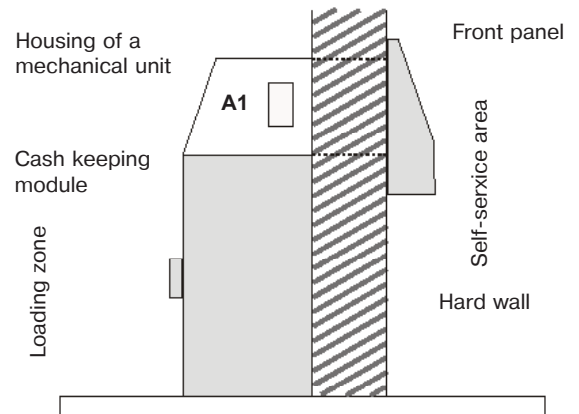

Figure 7 - Monitoring an automatic bank teller machine (ATM or bankomat)

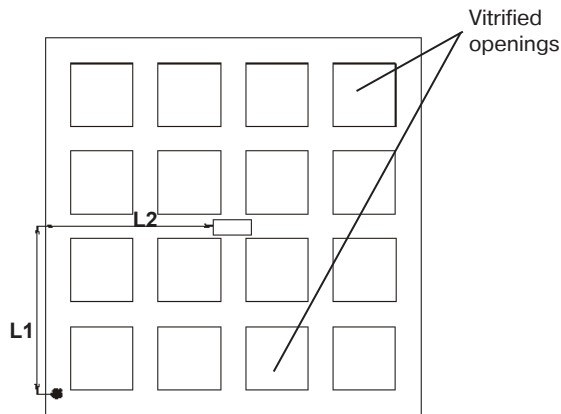

Figure 6 - Monitoring a window frame

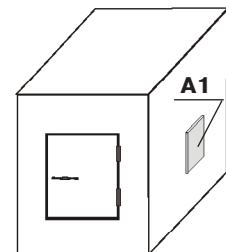

Figure 8 - Monitoring a safe