



PASSIVE INFRARED DETECTOR

«FOTON-20B»



Installation Guide

1 General Information

Passive infrared detector «Foton-20B» (hereinafter, the Detector) is designed for detecting intrusion into indoor protected area and generating alarm message by relay output contacts opening.

The Detector ensures case tamper protection by «Tamper» relay contacts opening.

The Detector has immunity to:

- small pets: mice, rats, birds in cages at a distance not less than 2.5 m;
- ambient background illumination and radio interferences.

The Detector is distinct in design, ease of installation, and maintenance. It provides possibility of a wall, corner or ceiling installation by means of a swivel bracket.

2 Features

- Dual-element pyrodetector.
- Temperature compensation of detectability.
- Vertical curtain detection zone with high filled density and high detection ability.
- Immunity to insects intrusion to the pyrodetector.
- Microprocessor-based signal processing.
- Possibility of the following modes choosing:
 - Detection zone testing;
 - Alarm memory;
 - LED indication.
- Self-testing fulfillment.
- Swivel bracket for the detection zone repositioning is supplied.

3 Specifications

Table 1

| Parameter | Value |
|------------------------|--|
| Detection zone | 15 m |
| Power supply | 9 – 15 V DC, current 15 mA |
| Output relay contacts | Energized Form A (NC) relay Current 30 mA, 42 V |
| Alarm message duration | Not less than 2 sec |
| Detection zones | Vertical curtain, 8 zones |
| Detection range | Adjusted by jumper «1» (15 or 10 m) |
| Operating temperature | minus 30 ... +55 °C |
| Relative humidity | 98 % at +25 °C without moisture condensation |
| Dimensions | not more than 92 x 57 x 48 mm |
| Weight | not more than 80 g |

The Detector detection zone pattern is shown in Figure 1.

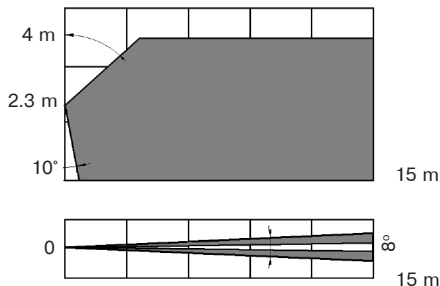

Figure 1 – Detection Zone Pattern

4 Scope of Delivery

Each Detector unit package contains the items listed in Table 2.

Table 2

| Name | QNT |
|---|--------|
| Passive infrared detector «Foton-20B» | 1 pc. |
| Swivel bracket | 1 pc. |
| Screw 3-3x30.016 | 2 pcs. |
| Passive infrared detector «Foton-20B». Installation Guide | 1 copy |

5 Field of Application

The Detector can be installed in flats, shops, offices, museums, industrial facilities.

6 Choosing the Place of Installation

The Detector is designed for operation in the closed areas. When choosing the Detector installation place, take note of the fact that the detection zone may be limited by non-transparent objects (curtains, houseplants, cabinets, bookcases, etc.), as well as glass and mesh partitions. There must be no windows, air conditioners, space heaters or heating radiators in the Detector detection range.

When installing the detector, fulfill its positioning in such a way, that the expected paths of intrusion would cross the sensitivity zones of the detector.

Recommended installation height:

- without swivel bracket – 2.3 m;
- with the use of the swivel bracket – 2.3 – 3 m (on condition that the detection zone is aligned);
- loop wires should be located far enough from power feed cables.

7 Installation

Unfasten the latch at the underside of the detector case by means of screwdriver and remove the detector cover (Figure 2).

Swivel Bracket Components

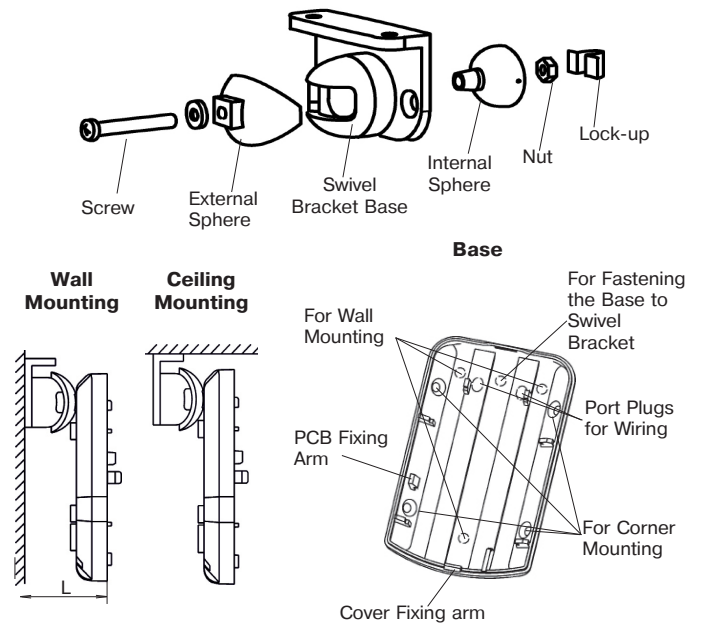

Figure 2 – The Detector Base and Swivel Bracket

- Drill holes in the detector base (Figure 2) for wires installation and for the detector fastening.
- Choose the place of installation, mark the places for mounting holes with the regard to detector base (or swivel bracket) openings, drill the holes in the wall.
- Pull the wires through the mounting holes in the base.
- Leave several centimeters of wire for its fastening inside the case.
- Fix the base of the detector at the chosen place.

Note – In case of mounting on the swivel bracket, unscrew the cap screw (M3x20 available) from the swivel bracket sphere. Keeping hold the swivel bracket assembled, fit the square bulge of the swivel bracket external sphere with the corresponded opening on the detector base. Plug in the screw into the opening in the top of the detector base and fix the connection by the screw with the forcing, ensuring the base rotation about the swivel bracket.

- Turn the base to the left and then to the right end points and fasten the swivel bracket on the wall by screws. Set the detector base in operative position and fasten it by swivel bracket cap screw M3x20.
- Put the PCB on its place, if it was removed.

8 Connection

The terminals for the detector connection are located at the PCB top. Fulfill connections in accordance with the:

- Figure 3 a) for connection to single alarm loop;
 - Figure 3 b) with tamper control connection to a singular loop.
- Set «1», «2», «3», «4» switches to position in accordance with their particular usage conditions and Cl. 9 of herein Installation Guide. DIP-switches application is shown on the Detector PCB. Close the Detector cover.

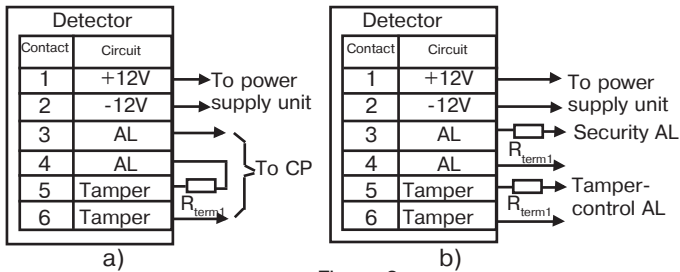

Figure 3

9 DIP-Switches Setting

Table 3

| Mode | DIP-switch | DIP-switch Position | |
|------------------------|------------|---------------------|------------------|
| | | ON | OFF |
| Alarm Memory | «4» | Memory ON | Memory OFF |
| Alarm Indication | «3» | ON | Disabled |
| Detection Zone Testing | «2» | Testing | Normal operation |
| Detection Range | «1» | Up to 15 m | Up to 10 m |

10 LED Indication

Two-color LED located on the front cover is used for the detector state indication.

Table 4

| Message | LED color | LED Indication state. Lighting time |
|-------------------------------|-----------|---|
| «Warm-up Time» | Red | Blinking during 45 sec at 1Hz frequency after the detector energizing |
| «Norm» | - | No LED indication |
| «Alarm» | Red | LED is ON for 3 sec |
| «Failure» | | Single triple-flash lighting with 4 sec period in accordance with CI.15 |
| «Alarm Memory» | Green | LED is ON in 5 min after «Alarm» message generation for 15 min |
| Detection Zones Determination | Green | Switching on for 0.25 sec at each detection zone beam crossing. The mode duration – 5 min after «Warm-up Time» mode |

11 The Detector Switching On and Testing

To adjust 15 m detection range value, set up a switch «1» to ON position. If dimensions of the protected area require the detection range less than 10 m, it is recommended to set up a switch «1» to OFF position to provide higher sensitivity level. It is advisable to use this mode of the Detector operation in small rooms with severe interference conditions.

After Detector energizing, self-testing of the detector is going on during 1 minute. During this procedure voltage supply, environment temperature and amplification path tests are conducted, LED blinks red (independent of «3» DIP-switch position), relay contacts are opened.

During self-testing procedure fulfilment, no movements inside the detection zone should not take place, since the Detector is in process of adaptation to the surroundings, and any movement can prolong «Warm-up time» mode.

12 Functional Testing

Upon the «Warm-up time» mode expiry, the detector turns to standby mode, and is ready for alarm message generation.

The detection zone high filled density ensures to detect intruder moving both in «full length» and in «flexed» position.

Testing Mode

DIP-switches position: «3» – ON, «2» – ON.

This mode is intended for the each beam of the detecting zone positioning. In case of each beam crossing, the LED indicator switches for 0.25 sec. Optimal travel speed at maximum detection range – 0.5 m/sec.

Note – In this mode there is no LED indication of alarm message generated by relay contacts opening.

Under the movement absence in the secured zone, the LED indicator should not light. After 5 min testing the detector changes to normal operation mode (in case of DIP-switch position is ON, alarm message generation is indicated by LED indicator lighting during 3 sec).

Sensitivity Testing

DIP-switches position: «3» – ON, «2» – OFF.

This mode is intended for the Detector sensitivity appraisal (the travel length measured from the moment of detection till alarm message generation). The alarm message should be generated after 2 – 4 steps within the detection zone during 3 sec.

Wait for 8 – 10 sec after each alarm until the LED is off and continue walking across the detection zone.

Note – If the Detector fails to detect moving objects in the detection zone, it's position on the swivel bracket should be changed (In case of wall mounting the rotation angle in horizontal plane $\pm 45^\circ$, the tilt degree in vertical plane – not less than 20°).

13 LED Indicator Disabling

For the Detector operation masking, the mode of LED indicator disabling is provided. Set DIP-switch «3» is in OFF position. In this mode LED indicator is in operable state only during first minute after the Detector energizing, as well as in «Alarm Memory» and «Failure» modes.

14 Alarm Memory

DIP-switch «4» – ON.

LED indicator switches in 5 min after alarm message generation and is lighting green during 15 min. After changing DIP-switch «4» from ON to OFF position, «Alarm Memory» indication shutdown is executed.

15 Self-testing and Failure Indication

The Detector carries out self-testing automatically, processing:

- availability of the receiver with amplifier;
- power supply;
- ambient temperature.

In temperature range near to 36°C , the sensitivity threshold shift takes place with the detectability level raising.

The detector is generating the «Failure» message during 15 min under the following conditions:

- power supply decrease to 9.0_{-1}V DC – by relay contacts opening, repeated by LED indicator periodical single-shot blinking green;
 - ambient temperature rise over maximum allowed value – by relay contacts opening, repeated by periodical double-shot LED indicator blinking green;
 - negative result of receiver and amplifies testing – by relay contacts opening, repeated by periodical triple-shot LED indicator blinking green.
- In 15 min after elimination of failure reasons the Detector returns to switching on and testing mode. After changing DIP-switch «2» from ON to OFF position, «Alarm Memory» indication shutdown is executed.

ATTENTION! The Detector must be checked at least annually in order to test their performance.

16 Storage and Transportation

16.1 The Detectors in their original packing may be shipped by any transport means in covered vehicles (in railway, cars, trucks, sealed heated compartments of aircraft, ship cargo holds, etc). The storage room should be free from current-conducting dust, acid vapors, alkali and gases that cause corrosion and destroy insulation

16.2 The Detectors in their original packing may be stored not more than 3 months. During this period the Detector package should not have bloodshot spots and impurities.

16.3 Upon the expiry of 3 months, the Detector should be released from the package.

17 Manufacturer's Guarantees

The Manufacturer guarantees conformity of the Detector to it's Technical Specifications if conditions of transportation, storage, assembling and operation are observed. The guaranteed storage period is 63 months since the date of manufacturing the Detector.

The guaranteed period of operation is 60 months since the date of commissioning within the storage period guaranteed.

The Detectors that are found to non-conforming to it's Technical Requirements shall be repaired by the Manufacturer, provided the installation and operation rules have been complied with.

18 Acceptance and Packing Certificate

Passive infrared detector «Foton-20B»,

serial number _____,

has been manufactured in compliance with the active technical documentation and classified as fit for operation and packed by «Development and Production Enterprise RIELTA» LLC.

Person in charge of acceptance and packing

QC representative _____ day, year, month

Rev. 4 of 30.10.2020

№00325

v1/v2.4

Made in Russia

«Development and Production Enterprise RIELTA» LLC

Petrogradskaya nab., 34, letter B, Saint Petersburg, Russia, 197046

www.rielta.com, rielta@rielta.com

Tel./fax: +7 (812) 233-0302, 703-1360, support@rielta.com

Technical support, tel.: +7 (812) 233-29-53, 703-13-57, support@rielta.com