



# RiDom

## Flood detector «Ri-FD-1i»



Installation guide

### 1 GENERAL INFORMATION

1.1 The flood detector «Ri-FD-1i» (hereinafter referred to as the Detector) control the emergence of water leaks from water supply and heating, with the transmission of notifications via a two-way radio channel in accordance with the protocol «Ri-Contact-Ri».

1.2 The Detector works as part of the smart home security system RiDom, communicating with the control center «Ri-HUB-1i» (hereinafter referred to as the Hub), that supports the radio channel exchange protocol «Ri-Contact-Ri».

1.3 Water leakage control is realized by measuring the resistance of the external circuit between the sensor terminals of the Detector.

1.4 The Detector does not require licensing and registration as a radio frequency device.

1.5 Two radio frequencies - the main and the backup - are used for the exchange of radio signals between the Detector and the Hub. The transition to the backup frequency happens automatically.

1.6 The status of the Detector is indicated by a two-color LED indicator.

1.7 The sensor generates and ensures the transmission of the following notifications over the radio channel:

- «normal status» when the resistance of the external circuit between its sensor terminals is 200 kOhm or more;
- «alarm» when the resistance of the external circuit between its sensor terminals is 100 kOhm or less;
- «opening» when the case is opened or the Detector is separated from the mounting surface;
- «discharge of the main battery» when the voltage of the main battery drops below 2.2-0.2 V;
- «discharge of the backup battery» when the voltage drops backup battery below 2.2-0.2 V;
- «Binding» mode;
- «Identification» mode;
- the quality of communication.

1.8 Radio exchange is initiated by the Detector with a period of 10, 15, 30, 60 seconds, and 2, 5, 10 minutes. Frequency of radio sessions is adjusted when setting up the Detector. Notifications of alarm and case opening are transmitted immediately.

1.9 The Detector is designed for continuous round-the-clock operation.

1.10 The Detector is resistant to electromagnetic interference.

### 2 SPECIFICATIONS

Table 1

Parameter	Value
Frequency range	865...867 MHz
Radiation power, no more	25 mW
Protection class	IP65
Battery type	CR2450, 2 pcs
The duration of the sensor operation from one battery under normal climate conditions and with communication period of at least 60 seconds:	
- main battery	60 months
- back up battery	2 months
Dimensions	65x55x20 mm
Weight	50 grams
Average service life	8 years
Operational conditions	
Operating temperature range	-20... +55 °C
Permissible air humidity at a temperature of +25 °C, without moisture condensation	Up to 98 %

### 3 SCOPE OF SUPPLY

Table 2

Name	Qty.
Flood detector «Ri-FD-1i»	1 ps
Screw bolt 3-3x30.016	1 pc
Lithium battery CR2450	2 pcs*
Installation guide for the «Ri-FD-1i»	1 copy
* Included	

### 4 VIEW AND DESIGN

In order to open the Detector case cover, insert a screwdriver into the gap and press it down with force.

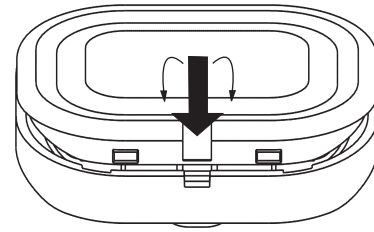

Picture 1

The Detector consists of the following elements (Picture 2): the base of the case with an opening mounting hole (7) and holes for sensor outputs (8), and the case cover with a printed circuit board (1).

The following elements are located on the printed circuit board:

- the main battery holder (2);
- RESET contacts (3);
- the backup battery holder (4);
- sensor outputs with installed sealing rubber bands (5);
- tamper switch (6).

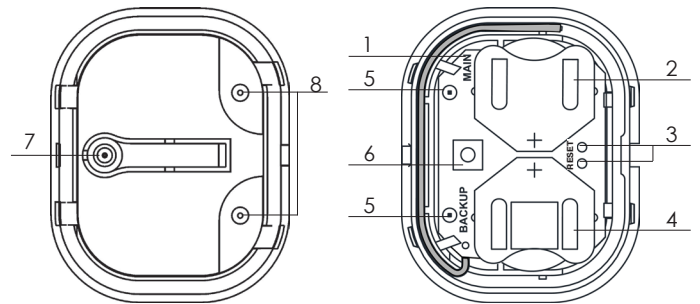

a) case base

b) case cover with PCB

Picture 2 – «Ri-FD-1i» view

### 5 INDICATION

The Detector generates the following types of indication:

- the «Linking» mode;
- «Identification» turns on when the appropriate command is received from the Hub and remains for 15 minutes or until the case is opened;
- indication of the Detector status turns on and remains for the first 15 minutes after the case is closed in the absence of other types of indications, provided that during this time the notification «Tampering» is not generated or the command from the Hub is not transmitted to disable the indication.

The indication modes are listed in the Table 3.

Table 3

LED status	Indication	Notes
«Linking»	Periodic green LED flashing	Registration in the HUB
Completion of «Linking»	Turning on the red LED for 2-3 s	
«Identification»	Alternating red and green LED light	The corresponding command was received from the Hub
«Alarm»	Single red LED light with a period of 4 seconds	Status indication is on and «Identification» indication is off
Connection quality assessment	See the section «Connection quality assessment»	
«Normal»	Off	

### 6 CHOOSING THE PLACE OF INSTALLATION

The Detector should be installed indoors only. Install the Detector in a place where the quality of communication is evaluated as «good» or «excellent».

**DO NOT install the Detector if the following cases:**

1. In close proximity to electrical wiring.
2. Outdoors.

### 7 CONNECTING THE DETECTOR TO THE SYSTEM

7.1 Open the RiDom application in the My Devices tab, click **+** and then press **Add device** button. Select the «Ri-FD-1i» detector from the list of devices and follow the prompts of the application.

7.2 Open the case (Figure 1).

7.3 When prompted by the application, remove the battery isolator.

7.4 The Detector will periodically turn on the green LED indicator; it indicates that the Detector is in the «Linking» mode.

7.5 Upon successful connection to the Hub, the LED indicator will turn red for 2-3 seconds, then you can see the Detector in the application, as well as all the corresponding information about the Detector. The «Linking» mode time is limited to 70 seconds.

7.6 To resume the «Linking» mode, you need to briefly close short the RESET contacts with a screwdriver for 2-3 seconds.

7.7 Install the case cover back.

## 8 CONNECTION QUALITY ASSESSMENT

8.1 In order to assess the quality of radio communication between the Detector and the Hub it is necessary to do the following:

- first install the backup battery in the holder (4), and then the main battery in the holder (2), or remove the insulators in the same sequence;
- place the Detector in the intended mounting place;
- press and then release the tamper switch.

8.2 When the tamper switch is released, the Detector generates a case tamper notification, transmits it over the air and displays the quality of radio communication with the Hub in accordance with Table 4.

Table 4 - Connection quality indication

Indication		Connection quality	Recommendations
Color	Mode		
Green	Three blinks	Perfect	Installation in this location is allowed
Green	Two blinks	Good	
Green	One blink	Weak	Choose a different installation location or use a repeater
Red	Multiple blinks	No connection	

## 9 INSTALLATION

9.1 Attach the base to the mounting surface.

The main way to attach the Detector is to stick the base to the mounting surface with double-sided adhesive tape. In order to securely mount the Detector, you should:

- make sure that the mounting surface is flat, dry and clean;
- remove the protective film from the working surface of the adhesive tape;
- firmly press the Detector to the mounting surface and hold it for 2-3 seconds.

To ensure the reliable mounting the Detector is attached to the place of installation with a screw through the opening mounting hole (7) (Picture 3).

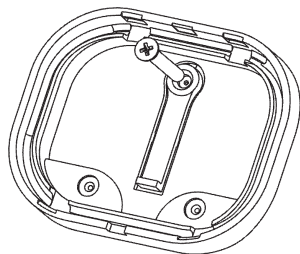

Picture 3

9.2 Install the cover with the printed circuit board into the base according to Picture 4. The Detector leads (5) must fit into the holes (8).

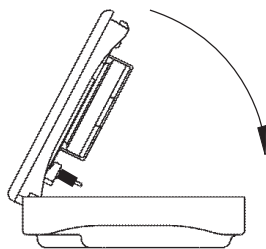

Picture 4

**Attention!** Do not leave the Detector turned on when the Hub is turned off for a long time. This will save battery life.

## 10 STORAGE AND TRANSPORTATION

- 10.1 The Detectors in their original packaging are resistant to:
- transport jolting with the acceleration up to 30 m/sec<sup>2</sup> at impact frequency range from 10 to 120 per minute or 15 000 strikes;
  - ambient temperature range minus 50 ... +55 °C;
  - relative air humidity (95 ± 3) % at a temperature +35 °C.

10.2 The Detectors in original package may be transported by any means of transportation in closed vehicles over any distances in compliance with the existing shipping rules concerning the respective means of transportation.

10.3 After transportation under the conditions different to exploitation conditions the Detectors shall be ready to operate after a maximum of six hours.

10.4 During storage period lithium batteries should be removed from the holders or isolators should be installed.

**Note:** The storage premises should not contain any current-conducting dust, acid and alkali fumes, or corrosive or destroying insulating gases.

## 11 DISPOSAL INFORMATION

11.1 The Detector does not contain precious metals, hazardous or toxic substances that can harm human health or the environment, and does not pose a danger to life, human health and the environment at the end of its service life.

11.2 In this regard, the disposal of the Detector can be carried out according to the rules for the disposal of general industrial waste.

## 12 MANUFACTURER WARRANTY

12.1 LLC NPP RIELTA guarantees that the Detector meets the requirements of technical specifications within 39 months from the date of manufacture, subject to the conditions of transportation, storage, installation and operation.

12.2 Warranty period of operation of the Detector is 36 months from the date of commissioning within the warranty period of storage.

12.3 If during the warranty period the Detector, which is subject to the rules of transportation, installation and operation, is found to be inconsistent with the requirements of the technical specifications, it is to be replaced or repaired by the manufacturer.

**Note** - Lithium batteries are not covered by the warranty.

## 13 DATE OF MANUFACTURE

\_\_\_\_\_ month, year



ridom.ru

Made in Russia

v10.1