



RiDom

Motion curtain and glassbreak detector «Ri-MGBD-1Ci»



Installation guide

1 GENERAL INFORMATION

1.1 Motion curtain and glassbreak detector «Ri-MGBD-1Ci» (hereinafter referred to as the Detector) detects movement in the protected area of a closed room and transmit notifications via a two-way radio channel in accordance with the «Ri-Contact-Ri» protocol.

1.2 The Detector works as part of the smart home security system RiDom, communicating with the control center «Ri-HUB-1» (hereinafter referred to as the Hub), via the radio channel protocol «Ri-Contact-Ri».

1.3 The Detector does not require licensing and registration as the radio frequency device.

1.4 The Detector combines two independent detection channels:

- passive sound acoustic channel (hereinafter – AC channel);
- passive optical-electronic, infrared channel (hereinafter – IR channel).

The AC channel detects the destruction of structures made of glass, as well as glass blocks.

The IR channel detects attempts to enter the secured space of a closed room.

1.5 The Detector is resistant to external illumination and radio interference, as well as interference caused by small animals like mice, rats, birds in cages at a distance of at least 2.5 m.

1.6 The Detector can be installed directly on the wall or in the corner of the room.

1.7 The Detector generates and transmits seven types of notifications over the radio channel:

- normal status;
- alarm;
- opening of the case or removal from the mounting surface;
- the battery discharge;
- «Linking» mode;
- «Identification» mode;
- communication quality assessment.

1.8 Detector is designed for continuous round-the-clock operation.

1.9 The Detector ensures pet immunity to cats and dogs up to 40 kg.

1.10 The Detector is resistant to electromagnetic interference.

2 FEATURES

- Sensitive elements: dual area pyroelectric receiver for IR channel and microphone for AC channel.
- Spherical lens ensures high detectability.
- Digital signal processing.
- Adjustable sensitivity of AC and IR channels.
- Up to 40 kg pet immunity.
- Protection against penetration of insects to the pyro receiver chamber.

3 SPECIFICATIONS

Table 1

Parameter	Value
Frequency range	865...867 MHz
Radiation power, no more	25 mW
Maximum detection range:	
- AC channel for glass area (R):	more than 1 m ² 10 m less than 1 m ² 6 m
- IR channel	12 m
Sensitivity:	Selectable:
- AK channel (HF):	
- level 3 (max)*	3
- level 2	2
- level 1	1
- level 0 (min)	0
- IR channel	12 m
Minimum area of protected glass	0,1 m ²
Warm-up time	Less than 60 seconds
Protection class	IP30
Battery type	CR123A, 1 pc.
Dimensions	109x57x44 mm
Weight	0,1 kg
Battery life at 60 seconds period	30 months
Average service life	8 years
Operational conditions	
Operating temperature range	-20... +55 °C
Permissible air humidity at a temperature of +25 °C, without moisture condensation	Up to 98 %
* Set by default	

4 DETECTION ZONE SCHEME

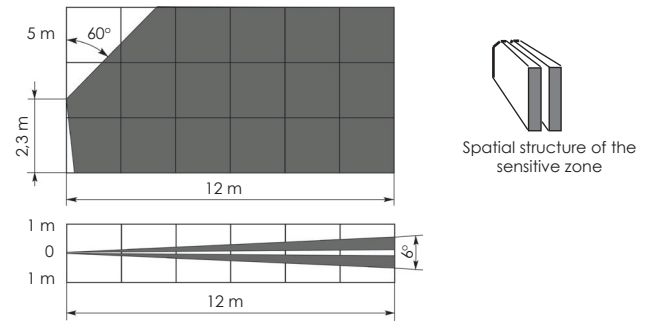

Picture 1 – Diagram of IR detection area

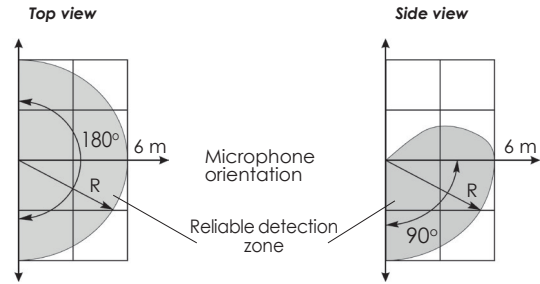

Picture 2 – Diagram of AC detection area

5 SCOPE OF SUPPLY

Table 2

Name	Qty.
Motion curtain and glassbreak detector «Ri-MGBD-1Ci»	1 pc.
Lithium battery CR123A	1 pc.*
Bracket	1 pc.**
Installation guide for the «Ri-MGBD-1Ci»	1 copy.
* Installed	
** Supplied by request	

6 VIEW AND DESIGN

The Detector consists of a case base (1), a hatch (2), a case cover (3) with an installed printed circuit board (4).

The following elements are located the printed circuit board:

- tamper switch (5);
- battery holder (6);
- pyro receiver (7);
- microphone (8);
- RESET contacts (9);
- opening sensor (10).

When attaching the base to the bracket, use the screw (11).

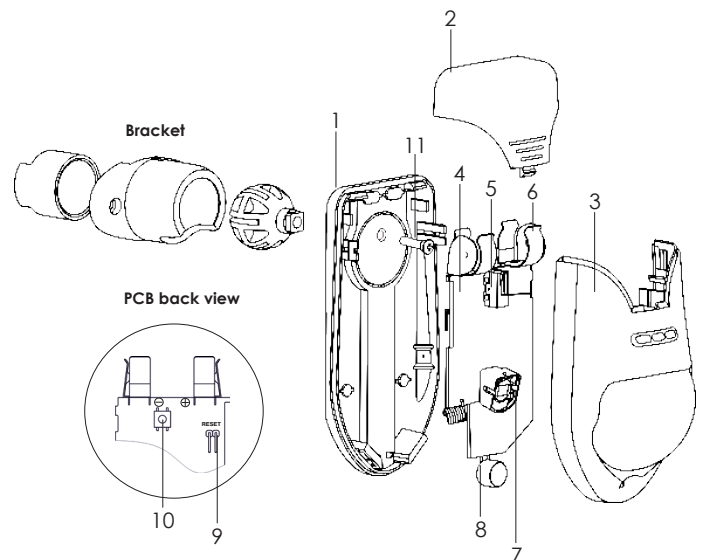

Picture 3 – Detector view

7 INDICATION

Table 3

LED status	Indication	Notes
«Linking»	Intermittent green LED	Inquiry for the registration of the Detector in the Hub
Completion of «Linking»	Turning on the red LED for 1 second	
«Connection lost» indication	4 times turning on of red LED	Data transmission attempts while connection is lost
«Identification»	Alternately turning on of the green and red LEDs	Upon receiving a corresponding command from the Hub
«Test» mode	Rare turning on of the green LED	
Connection quality assessment	See section «Radio area estimation»	

Notifications are indicated in accordance with Table 4.

Table 4

Status	LED indication		Condition
	Red	Green	
Normal	OFF	OFF	No alarm
AC alarm	ON	ON	Alarm
IR alarm	ON	OFF	Alarm
Reduced power	-	-	Notification to the Hub
Interference frequency 1	-	-	-
Interference frequencies 2	-	ON	-

8 CHOOSING THE PLACE OF INSTALLATION

The Detector is designed for indoor installation only.

When choosing a location for installing the Detector, consider the presence of obstacles that impair the transmission of the radio signal.



The recommended installation height is 2.3 m from the floor.

To reliably exclude false alarms from pets, it is not recommended to deviate its position from the vertical by more than 2°, when installing the Detector.

DO NOT install the Detector if the following areas:

- At a distance of more than 6 m from windows or other protected glass structures, while the Detector case should be maximally oriented to the zone of possible penetration, if possible. In the case of monitoring a glass surface with an area of more than 1 m², the maximum distance to the Detector can be increased up to 10 m.
- In close proximity to electrical wiring.
- Near metal objects and mirrors that cause attenuation of the radio signal or shield it.
- Outdoors.
- In rooms with temperature and humidity beyond the permissible

9 CONNECTING THE DETECTOR TO THE SYSTEM

9.1 Open the RiDom application and click  in the My Devices tab. Then press  button. Select the «RI-MGBD-1C» detector from the list of devices and follow the prompts in the application.

9.2 Open the Detector case by sliding the top panel cover (hatch pos. 2, pic. 3).

9.3 When prompted by the application, remove the battery isolator.

9.4 The Detector will periodically turn on the green LED, which indicates that it is in the «Linking» mode. In the absence of the indication, close the «RESET» contacts with a screwdriver for 2-3 seconds.

9.5 Upon successful connection to the Hub, the indicator on the Detector will turn red for 2-3 seconds, then you can see the Detector in the application, as well as all the information about it. Linking mode time is limited to 100 seconds. To resume the «Linking» mode, briefly close the «RESET» contacts with a screwdriver again.

9.6 Install the hatch cover back.

10 RADIO CONNECTION QUALITY ASSESSMENT

To determine the possibility of using the Detector in the selected location, it is necessary to remove the hatch, after which the Detector will display the quality of radio communication with the Hub by means of the LED indication in accordance with Table. 5, then it will switch to the «Test» mode.

Table 5 – Indication of the communication quality control results

Indication		Connection quality	Recommendations
Color	Mode		
Green	Three blinks	Perfect	Installation in this location is allowed
Green	Two blinks	Good	
Green	One blink	Weak	
Red	Multiple blinks	No connection	Choose a different installation location or use a repeater

11 MOUNTING

- Remove the hatch;
- Remove the board with the cover (4,3) from the base (1) by pulling them towards you and down;
- Open the holes in the base of the Detector that will be used for fixing it to the mounting surface;
- Having chosen the location of installation, mark the holes for mounting the Detector, taking into account the position of the holes in the base, drill holes in the wall;
- Fix the base of the Detector in the chosen place;
- Install the PCB cover into the base.
- Insert the battery, close the hatch.
- Set the operating mode using the configurator according to the specific application (Table 1).

Dimensions (in mm):

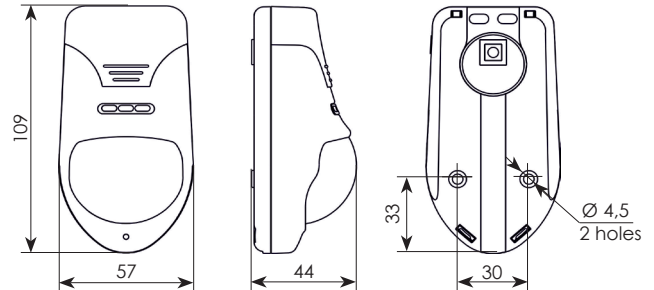

Picture 4

12 POWER ON AND CHECK

When the power is turned on, the Detector switches to standby mode within 60 seconds. This turns on the red and then green LEDs. The red LED blinks once, then the green LED turns on and blinks in accordance with the table. 5.

13 POWER FAILURE

When the supply voltage drops below 2.4 V, the notification «Main power failure» is issued on the Hub, and the notification «Reserve power failure» is issued below 2.2 V. Fault persists until power is off.

ATTENTION! The Detector must be checked at least once a year to check its performance.

14 STORAGE AND TRANSPORTATION

14.1 The Detectors in their original packaging are resistant to:

- transport jolting with the acceleration up to 30 m/sec² at impact frequency range from 10 to 120 per minute or 15 000 strikes;
- ambient temperature range minus 50 ... +55 °C;
- relative air humidity (95 ± 3) % at a temperature +35 °C.

14.2 The Detectors in original package may be transported by any means of transportation in closed vehicles over any distances in compliance with the existing shipping rules concerning the respective means of transportation.

14.3 After transportation under the conditions different to exploitation conditions the Detectors shall be ready to operate after a maximum of six hours.

14.4 During storage period lithium batteries should be removed from the holders or isolators should be installed.

Note: The storage premises should not contain any current-conducting dust, acid and alkali fumes, or corrosive or destroying insulation gases.

15 DISPOSAL INFORMATION

15.1 The Detector does not contain precious metals, hazardous or toxic substances that can harm human health or the environment, and does not pose a danger to life, human health and the environment at the end of its service life.

15.2 In this regard, the disposal of the Detector can be carried out according to the rules for the disposal of general industrial waste.

16 MANUFACTURER WARRANTY

16.1 LLC NPP RIELTA guarantees that the Detector meets the requirements of technical specifications within 63 months from the date of manufacture, subject to the conditions of transportation, storage, installation and operation.

16.2 Warranty period of operation of the Detector is 60 months from the date of commissioning within the warranty period of storage.

16.3 If during the warranty period the Detector, which is subject to the rules of transportation, installation and operation, is found to be inconsistent with the requirements of the technical specifications, it is to be replaced or repaired by the manufacturer.

17 DATE OF MANUFACTURE

_____ month, year



ridom.ru

Made in Russia

v10.2R